



mounting and operating instructions

KST-20 Vento | KST-20 Vento/CO2 | KST-20 Vento/RN
climate controller



ZILA GmbH
Neuer Friedberg 5
98527 Suhl

Tel.: +49 (0) 3681 867300
Fax: +49 (0) 03681 8673099

Web: www.zila.de
E-Mail: info@zila.de

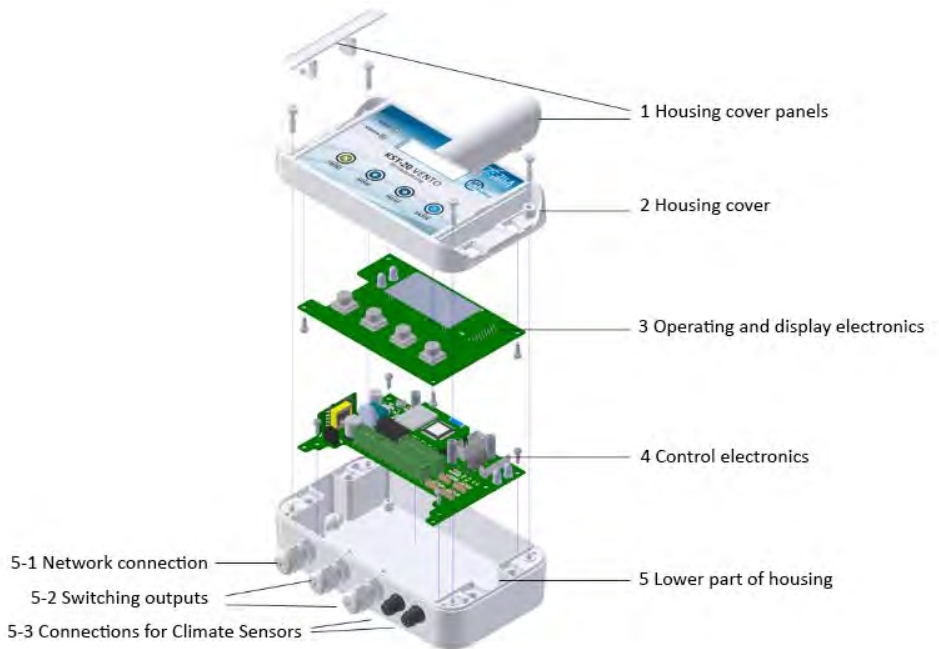

Index

1.	scope of delivery	3
2.	General notes	3
2.1.	installation personnel	4
2.2.	Used Pictograms	4
2.3.	Intended use	4
2.4.	Foreseeable misuse	4
2.5.	Safety Instructions	4
3.	product description	5
3.1.	Technical specifications	5
3.2.	Standards and Regulations	5
3.3.	aH-Controlled Technology	5
3.4.	Operating modes	5
3.4.1.	Dehumidifying (E)	5
3.4.2.	Ventilation (L)	7
3.4.3.	Cooling (K)	8
3.5.	Comfort functions	9
4.	assembly and commissioning	9
5.	connection of the actuators	11
5.1.	Control electronics	11
5.2.	Connection variants	12
6.	device functions	12
6.1.	Factory settings	12
6.2.	Display illumination	13
6.3.	Functions of the keys	13
6.4.	Menu navigation and configuration	13
6.4.1.	operating mode	14
6.4.2.	actuators	14
6.4.3.	antifreeze temperature (FS)	15
6.4.4.	Timer (Suhr)	15
6.4.5.	dry protection (TS)	15
6.4.6.	Time	15
6.4.7.	Date	15
6.4.8.	target moisture	15
6.4.9.	Delta aH	15
6.4.10.	Cool -TSP	16
6.4.11.	Speed Min/Max	16
6.4.12.	LEDs	16
6.4.13.	Error indication on the display ..	16
7.	circuit diagrams	16
8.	additions to the KST-20 Vento/CO2	18
8.1.	actuators	18
8.2.	CO2- Measurement	18
8.3.	Connection of the sensors	18
9.	additions to the KST-20 Vento /RN	19
9.1.	actuators	19
9.2.	Radon measurement	19
9.3.	Connection of the sensors	19
10.	device support	20

1. scope of delivery

- Climate Control KST-20 Vento
- Power cable
- Climate sensor inside (integrated or detached)
- Climate sensor outside (detached, max. 10m cable)
- mounting and operating instructions
- 2-pole plug (terminal 5)
- Wall mounting set

Components for device version RN or CO2

- Radon sensor (KST-20 Vento/RN)
- CO2-Sensor, integrated or detached (KST-20 Vento/CO2)

2. General notes

- Read safety instructions and keep the manual
- Installation, commissioning, electrical connection and repairs of the KST-20 Vento are only permitted by qualified persons.
- The specified protection class is only guaranteed if the cables are installed in the correct position and correctly inserted and connected.
- Only operate the device at the specified voltage
- Modification and conversion of the device is not permitted and releases ZILA GmbH from any warranty and liability



Please read these installation instructions carefully before using the KST-20 Vento air conditioning control unit. Follow the instructions. Keep these installation instructions in a safe place for future use.

2.1. installation personnel

Installation only by qualified persons.

The electrical connection should only be done by qualified electricians. They have an electrotechnical training and the knowledge of the dangers and effects that can be caused by an electric shock.

2.2. Used Pictograms



DANGER

Imminent danger, which leads to serious injury or death if not observed.



CAUTION

Potentially dangerous situation that could lead to minor to moderate physical injury.



ATTENTION

Possible situation that could lead to material damage to the product or its surroundings.



INFO symbol for important information and tips.

- Enumeration symbol for information on the respective topic.
1. Instructions. Carry out the specified instructions in sequence.

2.3. Intended use

The unit is used for the automatic and controlled activation of supply air and exhaust air elements for dehumidification, ventilation or cooling of cellars, storage and supply rooms, showrooms, offices, changing rooms and similar rooms.

Typical applications

- Dehumidification of rooms and buildings, such as cellars, archives, museums, churches
- Cooling of production halls and server rooms
- Ventilation of living spaces according to DIN 1946-6
- Ventilation of meeting and classrooms, sports halls and fitness studios

Operation is only permitted when:

- Fixed installation within buildings.
- Installation on a suitable wall.

2.4. Foreseeable misuse

ZILA is not liable for damages caused by improper use. Do not use the device under the following circumstances:

- in the vicinity of flammable materials, liquids or gases
- in potentially explosive atmospheres
- in outdoor areas without further protection

2.5. Safety Instructions

- Installation and electrical connection only by qualified persons.
- Read these operating instructions carefully before commissioning.
- Only operate the device with the voltage and frequency specified on the type plate.
- Do not make any changes to the device.
- Never operate the device without the electronics cover.

3. product description

The KST-20 Vento is a climate control with "aH-Controlled" technology for demand-oriented ventilation of private, commercial and industrial rooms of all kinds.

By means of the connected sensors the climatic conditions in the inside and outside area are determined and compared. According to the measured climatic conditions and the desired operating mode (dehumidification, cooling, ventilation), the unit controls supply air and exhaust air elements in a controlled manner. Additional dehumidification, drying or cooling systems can also be controlled.

Due to the integrated device functions and the large number of connectable devices, such as fans, window openers, louvre dampers, condensation dryers etc., the KST-20 Vento can be used flexibly in almost all living, working and industrial areas.

3.1. Technical specifications

- Power supply: 230V AC
- Protection class: IP 65
- Dimensions in mm (LxWxH): 160 x 90 x 50
- Separate connections for 230 V supply and exhaust air elements up to maximum 500 W
- 0...10 V control outputs (alternative to 230 V)
- Operating and surrounding conditions: 0...50°C

Further technical specifications can be found in the product-specific data sheet on our website <https://zila.de/>.

3.2. Standards and Regulations

The KST-20 Vento climate control system complies with the EMC directive 2014/30/EU under consideration of the following standards:

- EN 55014-1
- EN 55014-2
- EN 61000-6-2

3.3. aH-Controlled Technology



The basic principle of ZILA climate control systems is based on the comparison of the water vapour content of indoor and outdoor air.

The water vapor content is described by the absolute humidity (aH = absolute Humidity) and represents a dimension for the "actual" humidity in the air. The comparison of the absolute humidity of indoor and outdoor climate ensures that humid air is removed from rooms and only drier outdoor air is introduced.

"aH-Controlled" stands for the automated determination of suitable times for switching on the supply air and exhaust air elements by the climate control system, takes the climatic conditions inside and outside the building into account.

The climate control system controls the most common single-stage, two-stage and speed-controlled fans as well as motor-driven window openers and ventilation louvres fully automatically. aH-Controlled ensures a healthy building and a good indoor climate and also works extremely energy-efficiently, as the building is only ventilated when it is necessary and air exchange is useful.

3.4. Operating modes

With the KST-20 Vento you can choose between three operating modes: dehumidification, ventilation according to DIN 1946-6 and cooling.

Note:

To avoid failures and for optimum control behaviour of the KST-20 Vento climate control system, the actuator system suitable for the respective operating mode must be used.



3.4.1. Dehumidifying (E)

The KST-20 Vento climate control system is suitable in dehumidifying mode for mould prevention and

building protection as well as for maintaining a comfortable climate.

Controlled dehumidification is based on the comparison of absolute humidity. In this process, moist room air is exchanged with drier outside air. During normal operation, the following climate information is shown on the display:

- Relative humidity indoor/outdoor (rHi, rHa)
- Temperature inside/outside (Ti, Ta)
- Absolute humidity inside/outside (aHi, aHa)

The KST-20 Vento starts room dehumidification as soon as the absolute outside humidity is lower than the absolute inside humidity ($aH_{\text{inside}} < aH_{\text{outside}}$). The room is dehumidified in a ventilation cycle consisting of an active and a passive phase. The fan is switched on in the active phase. During the passive phase, the fan is off and the room air contaminated with moisture can mix with the supplied drier outside air. This permanent shock ventilation ensures efficient room dehumidification as long as the climatic conditions $aH_{\text{inside}} < aH_{\text{outside}}$ are fulfilled. A ventilation cycle for both the active and passive phases lasts 10 minutes. Depending on the type of fan, there are different possibilities for speed control.

Further information:

For information on the factory settings, refer to the "Factory settings" chapter



dehumidification by 1-stage fans

The KST-20 Vento works as an intelligent power switch and controls the active and passive phases of 1-stage fans.

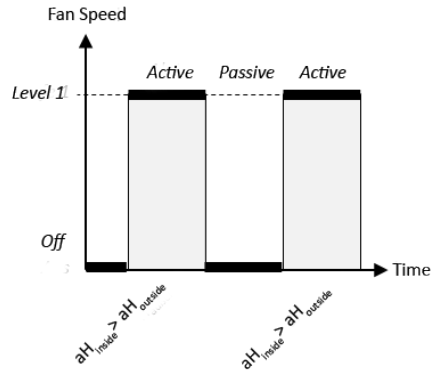

Dehumidification with 2-stage fans

2-stage fans can be operated at either a reduced or an increased speed during the active phase. The KST-20 Vento switches on the second stage if the following climatic conditions are given:

$$aH_{\text{inside}} > aH_{\text{outside}} + 5g/m^3.$$

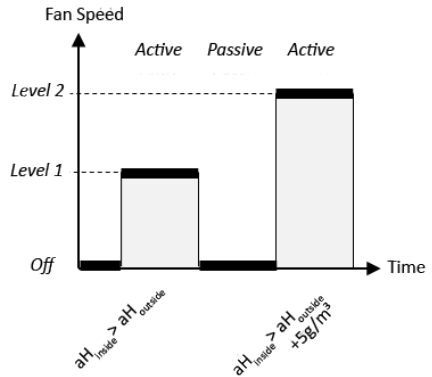

Dehumidification with speed-controlled fans

Speed-controlled fans are operated within the two adjustable limits "minimum speed" (DZMIN) and "maximum speed" (DZMAX). The speed corresponds to the control voltage in percent. The lower limit DZMIN starts by default at $aH_{\text{inside}} > aH_{\text{outside}} + 0,2g/m^3$. The upper speed limit DZMAX is activated at $aH_{\text{inside}} > aH_{\text{outside}} + 10g/m^3$. In between, the output of the control voltage is linear.

Definition of the speed:

The speed is defined at the beginning of an active phase and is maintained during this phase. Therefore, the speed is only adjusted again with a new active phase.

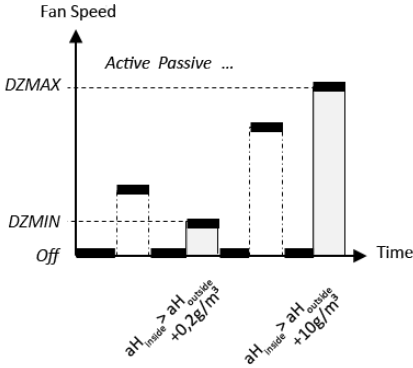

Dehumidification with electric window openers

Since motor-driven window openers only allow a limited number of switching operations, with this type of dehumidification the supply air and exhaust air elements remain switched on until the absolute humidity outside is no longer lower than inside.

Electric window openers:

The electrical control of window openers is different from that of the actuators mentioned above. To avoid malfunctions, it is essential to observe the corresponding circuit diagram and the correct actuator selection for the operating mode.



A ventilation interval does not take place if the temperature falls below the set frost protection temperature or the dry protection humidity.

Further information:

Further information on dry and frost protection can be found in section 3.5 „Comfort functions“



Restricted use in case of defects in building physics.

In the case of defects in building physics, water often penetrates through walls and the floor into the affected room. In such cases, the KST-20 Vento climate control system can be used as a supplement for dehumidification.

The unit supports the drying of masonry by means of a controlled air exchange, but cannot achieve complete dehumidification on its own.



3.4.2. Ventilation (L)

For living spaces, the device can be used in accordance with DIN standard 1946-6.

The KST-20 Vento climate control system then controls two-stage and speed-controlled fans in the basic ventilation and in an increased ventilation.

The connection of 2-stage or speed-controlled fans is necessary for this.

Interruption of the basic ventilation.

Basic ventilation can only be interrupted by pressing the PAUSE key on the air conditioning control.



Ventilation with 1-stage fans

Ventilation with 1-stage fans is not supported.

Ventilation with 2-stage fans

The climate control KST-20 Vento always controls the ventilation fans in the first stage (basic ventilation).

The increased ventilation stage sets in if $aH_{inside} > aH_{outside} + \Delta aH$ and if the relative humidity in the interior is higher than the desired or target humidity ($rH_{inside} > rfw$).

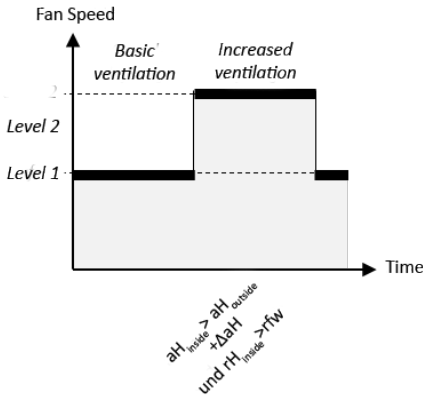

ΔaH stands for the minimum distance between the absolute humidity inside and outside. The default value is $5g/m^3$.

The desired humidity describes a desired humidity level in the concerned room, which must be maintained by the climate control system. The input range is between 40% and 60% of the relative humidity. This can be adjusted in 5% steps.

Ventilation with speed-controlled fans

In basic ventilation, the KST-20 Vento climate control system controls the speed-controlled fans at the minimum speed (DZMIN). To reach the maximum speed, the climatic condition $aH_{inside} = aH_{outside} + 10g/m^3$ must be fulfilled.

In between, the speed is controlled linearly depending on the climatic conditions.

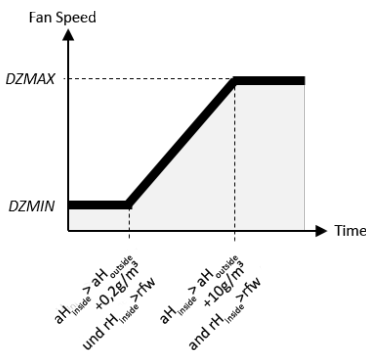

Basic ventilation only continues with DZMIN until the desired humidity is reached or the absolute humidity inside is lower than the absolute humidity outside.

3.4.3. Cooling (K)

By simply adjusting the configuration parameters, the device becomes a temperature-dependent cooling control for factory and production halls, server rooms and many other sensitive electrical systems.

cooling with 1-stage fans

In cooling mode, natural ventilation starts when the adjustable internal temperature limit (cooling TSP) is exceeded. When the ventilation is switched on, the temperature inside the room must be higher than the temperature limit and the outside temperature must be at least $2^\circ C$ colder than the inside temperature.

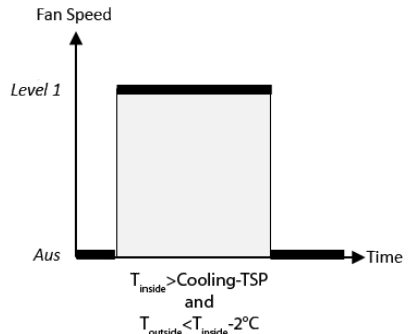

Control of cooling aggregates

In the case that $T_{inside} > \text{Cooling-TSP}$ is given, but the difference to the outside temperature $T_a > T_i - 2^\circ C$ does not apply, it is possible to operate a cooling unit in combination with a single-stage or speed-controlled fan at the second output of the climate control.

Cooling with 2-stage fans

If 2-stage fans are connected, the second stage is switched on if the following climatic conditions are given:

$$T_{inside} > T_{outside} + 5^\circ C.$$

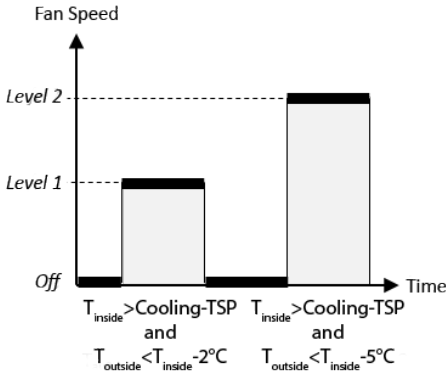

Cooling with speed-controlled fans

When speed-controlled fans are used, the control is carried out between the two adjustable limit values DZMIN and DZMAX as a percentage value of the control voltage (0-10VDC).

If the condition $T_{inside} > T_{outside} + 2^{\circ}$ is given, the speed-controlled fan is activated with the minimum speed (DZMIN). If $T_{inside} = T_{outside} + 9^{\circ}\text{C}$ the fan is operated at full speed (DZMAX).

In between, the speed is controlled linearly depending on the temperature conditions.

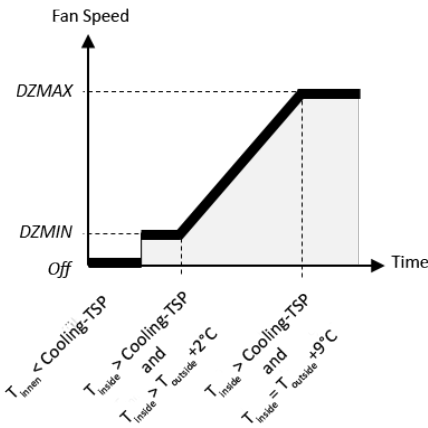

3.5. Comfort functions

Integrated time switch

With the integrated timer, active times for the ventilation units can be set. In this way, the ventilation remains switched on in the specified time window regardless of the climatic conditions.

Frost protection

The frost protection function prevents the monitored room from cooling down too much due to ventilation when outside temperatures are close to freezing point. For this purpose, a temperature is set for the outside area at which the climate control dispenses with ventilation cycles, even if the climatic conditions would allow ventilation.

- Standard setting: 3°C
- Input range between $0-5^{\circ}\text{C}$ in 1% steps

The frost protection function can be deactivated by setting the value to 99.

Dry protection

Too dry room air disturbs the well-being. Dust and other particles cannot be bound without sufficient humidity.

The dry protection function ensures that the humidity in the monitored room remains at a healthy level for people and the building.

For this purpose, a desired humidity in the range between 40% and 60% of the relative humidity can be set in 5% steps in the control menu.

4. assembly and commissioning

The correct installation position is horizontal.

The device can be mounted on a wall in a few steps.

1: To install the unit and to connect the power cable and the supply air and exhaust air elements, open the housing cover panels (1) on the left and right edge of the housing cover by folding them open.

2: Mark the 4 drill holes as provided.

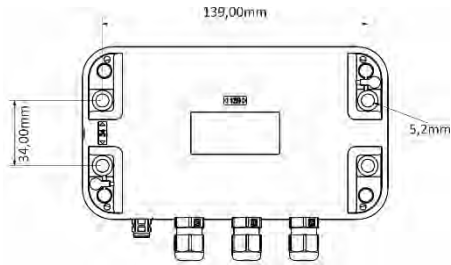

3: Mount the unit at a suitable place on the wall by inserting the screws through the holes provided in the housing and fastening the screws.

5: Connect the power cable as well as the actuators by passing the cables through the gland and connecting them to the appropriate terminals. The terminal blocks can be removed for this purpose.

Attention: For detailed information on the electrical connection of the actuators, please refer to the section "Actuator connection".



4: Remove the housing cover (2) after loosening the 4 screws.

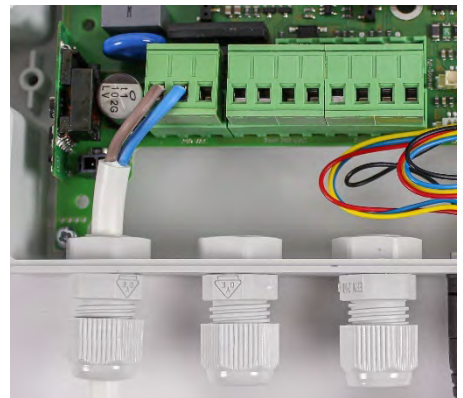

6: When all electrical cables are correctly connected, place the housing cover (2) back onto the lower part of the housing (3) and fasten it by loosening the screws.



7: Finally, close the housing cover panels (1) on the left and right edges.



8: Connect the outdoor climate sensor to the corresponding socket on the right side of the bottom of the housing. If a remote indoor climate sensor is included in the scope of delivery, repeat the procedure for this sensor as well.

Avoid damage:

The climate sensor fits only one of a certain position into the socket provided. Make sure that you insert the plug in the correct position, otherwise the appliance may malfunction and be damaged.



9: To complete commissioning, plug the power plug into the power socket. The unit is then switched on.

5. connection of the actuators

The KST-20 Vento climate control system serves as an intelligent mains switch and can also control speed-controlled devices. Various connections are available on the climate control system for this purpose. Thus, several supply air and exhaust air elements can be combined with each other and, if necessary, supplemented by drying or cooling devices.

The following typical devices can be connected alternatively or in combination

- 1-stage ventilation fans (230V AC)
- 2-stage ventilation fans (230V AC)
- Speed controlled fans (0...10V DC)
- Motor driven window opener (230V AC)
- Ventilation flaps (up to 48V DC)
- Drying and cooling units (230V AC)

5.1. Control electronics

Danger to life:

Danger to life from electric shock.
Disconnecting the device from the power supply.



The KST-20 Vento has 5 terminal blocks (KL).

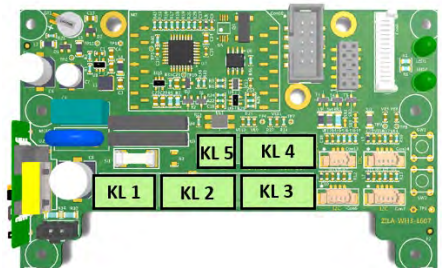

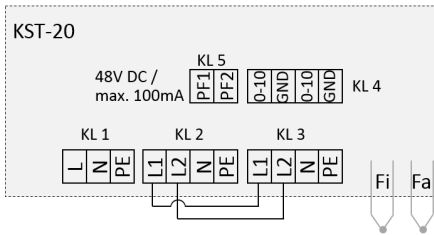

Key to abbreviations:

- KL 1: Power supply 230V AC
- KL 2 and KL 3: 230 V Switching outputs
- KL 4: 0...10 V Control outputs
- KL 5: Potential-free output
- Fi und Fa: Climate sensor connections

- L, L1, L2: Phase
- N: Zero
- PE: Protective earth
- PF1, PF2: Potential-free contact
- 0-10: 0...10 V DC analogue output
- GND: Ground

	Dehumidify	Cooling	Ventilation
1-stage fan for supply air and exhaust air			-
1-stage fan and window opener		-	-
1-stage fan and condensation dryer or cooling unit			-
2-stage fans for supply air and exhaust air			
Speed-controlled fans for supply air and exhaust air			
Speed-controlled fans and window openers			
Speed-controlled fans and condensation dryer / cooling unit			-

– Unsupported connection variant

Connector:

To use the potential-free output, please use the supplied 2-pole plug. The plug for terminal block 4 can only be used as an alternative to terminal block 3. Replace if necessary.



The supply air and return air elements are switched with the same unit logic, so that the connections L1 and L2 of KL 2 and KL 3 are connected in the unit.



6. device functions

6.1. Factory settings

If the MODE button is pressed when the instrument is switched on, the instrument changes to the factory settings. The following values are set:

- Operating mode: Dehumidify
- Actuation: 1-stage fan
- Parameters are set to default settings

You can then set the respective duration for the dehumidification operating mode, with which the actuators remain switched on or off.

Use the "right arrow" button to skip this setting and exit the factory settings menu.

With the ENTER key you change the menu level and can change the settings one after the other for the active time and passive time between 10 and 60 minutes.

5.2. Connection variants

The possible connection combinations that can be used in the three different operating modes are shown below. The detailed wiring diagrams can be found at the end of this manual.

6.2. Display illumination

If no key is pressed on the control unit for longer than 1 minute, the air conditioning control unit automatically switches off the background lighting of the display. Pressing any function key switches, the display lighting back on.

6.3. Functions of the keys

All four operating keys on the device are basically equipped with at least two functions. One is the function which is illustrated on the key and the other is the function described by the text below the key.



Key „Trend“

In the dehumidifying mode, pressing the TREND key resets the trend value, i.e. the current value for the absolute humidity in the interior is stored as a reference value for the subsequent dehumidification success. This should be done after the unit has been put into operation. The dehumidification success can be checked later during normal operation by pressing the PAUSE key.

If, however, the timer is active, it is deactivated by pressing the TREND key.

Observe operating mode!

Tendency reset and deactivation of the timer refer to the dehumidification operating mode.



On the first level of the configuration menu, pressing the TREND key takes you back to the menu item „Start measurement“.

Key „Mode“

In normal operation, a manual ventilation process can be started by pressing the MODE button.

In the configuration menu, the MODE key can be pressed to scroll to the left.

When the device is switched on, pressing the MODE button takes you to the factory settings.

Key „Pause“

During normal operation, the automatic mode can be interrupted with the PAUSE key. The display will then show the stored reference value for absolute humidity with the corresponding date and, on the second line of the display, the current value for the absolute humidity in the interior.

Key „Enter“

Press the ENTER key to open the configuration menu and confirm the entries made within the menu.

If the menu item "Start measurement" is confirmed by pressing ENTER, the instrument exits the menu and changes to the automatic mode.

6.4. Menu navigation and configuration

The selected operating mode is indicated in the unit display by the letters **E for dehumidification, L for ventilation and K for cooling**.



In addition, the selected actuator system is indicated at the end of the second line by the corresponding character.

- 1= 1-stage fan
- 2= 2-stage fan
- D= speed-controlled fan
- F= Window opener in combination with 1-stage fan
- R= Window opener in combination with speed-controlled fan

In the dehumidification operating mode, the values for run through one after the other in normal operation:

- Relative humidity indoor/outdoor (rHi, rHa)
- Temperature inside/outside (Ti, Ta)
- Absolute humidity inside/outside (aHi, aHa)

The unit is configured from normal operation by pressing ENTER. The current climate control is interrupted and the menu appears. The first line of the display shows the relevant menu, while the second line provides operating instructions.

The menu is structured from left to right. The MODE and PAUSE keys are used to scroll through the menu.

Faster operation:

In the first level of the menu, the TREND key causes the menu to jump to the item "Start measurement". From here, the ENTER key can be used to start normal operation.



6.4.1. operating mode

The selection of the desired operating mode is the first setting to be made. Press the ENTER button to open the setting. Then use the arrow keys (MODE, PAUSE) to select between E (dehumidification), L (ventilation according to DIN 1946) and K (cooling). Press the ENTER key again to confirm the selection. The menu is updated according to the operating mode, so that some functions are activated or hidden.

6.4.2. actuators

The connected actuators must be selected from the menu in the same way as described above for the operating mode.

The following options are available:

- 1 = 1-speed fans (not in ventilation mode)
- 2= 2-stage fans (for all operating modes)
- D = Speed-controlled fans (for all operating modes)
- F = Window opener in combination with 1-stage fan (only in dehumidifying mode)
- R= Window opener in combination with speed-controlled fan

Connecting the devices:



The supply air and exhaust air elements are switched with the same unit logic, so that the connections L1 and L2 of KL 2 and KL 3 are connected in the unit. The available connection combinations can be found at the end of the instructions.

Unit versions of two-stage fans:



Depending on the manufacturer of the two-stage fan to be connected, settings must be made in the menu:

In the menu "Actuators" first select "2" and confirm the selection with ENTER. Then press the TREND button to enter the selection for the type of two-stage fan. Select the appropriate configuration according to the circuit diagram of the fan.

Version 2-1
Connection

Version 2-2
Alternate switching

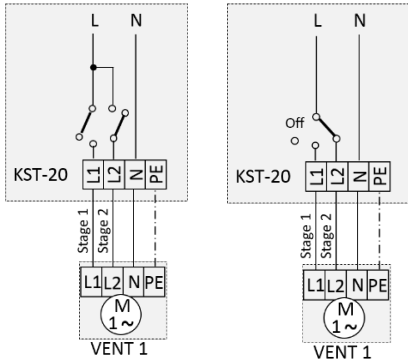

6.4.3. antifreeze temperature (FS)

This option is only available in the dehumidification mode.

The anti-freeze temperature setting ensures that ventilation does not take place if the outside temperature is too low. The setting range is 0°C-5°C. The default setting is 3°C.

6.4.4. Timer (Suhr)

This option is only available in the dehumidification mode.

If 00:00 is entered in the menu for both the switch-on and the switch-off time, the time switch function is switched off.

Otherwise, ventilation will run in the specified time range with the appropriate actuators without taking the actual climate values into account.

The setting is made according to the following scheme:

- Enter the switch-on time [hh] ENTER [mm] ENTER
- Entering the switch-off time [hh] ENTER [mm] ENTER

During normal operation, a running timer function can be switched off using the TREND key.

6.4.5. dry protection (TS)

This option is only available in the dehumidification mode.

The dry protection function ensures that the relative humidity in the corresponding room is not too low.

The input range is between 30% and 40% of relative humidity.

6.4.6. Time

This option is available in all operating modes.

The input of the current time is especially important for the timer. After setting the time for the first time, the time is retained and continues to count automatically.

Continuously pressing the PAUSE key will cause the numbers to scroll faster.

6.4.7. Date

This option is available in all operating modes.

After the first setting, the date is retained and continues to count independently. Continuously pressing the PAUSE key will cause the numbers to scroll faster.

6.4.8. target moisture

This option is only available in the ventilation operating mode.

The target humidity describes a desired humidity level in the room concerned, which must be maintained by the climate control system.

The input range is between 40% and 60% and can be set in 5% relative humidity steps.

6.4.9. Delta aH

This option is not available in cooling mode.

This setting is only activated if 2-stage ventilation units are connected.

The setting refers to the switching threshold for the second ventilation stage.

The input range is between 5 and 10 g/m³.

6.4.10. Cool -TSP

This option is only available in cooling mode.

The device parameter Temperature switching threshold for cooling defines the switching threshold for the cooling operating mode.

The input range is between 24°C and 30°C for the indoor temperature.

6.4.11.Speed Min/Max

This option is available in all operating modes if speed-controlled fans are connected and selected in the actuators.

The input range of the lower speed threshold is 10% to 30% from 0-10VDC and can be adjusted in 5% steps.

The input range of the upper speed threshold is 70% to 90% from 0-10VDC and can be adjusted in 5% steps.

6.4.12. LEDs

Mode LED

- On: Normal operation
- Flashing: manual mode

Status LED

- On: actuators on
- Off: actuators off

6.4.13. Error indication on the display

- Error indoor sensor
- Error external sensor
- System Error XX

ATTENTION:

If the error messages appear, please contact ZILA Support.



7. circuit diagrams

Two 1-stage fans

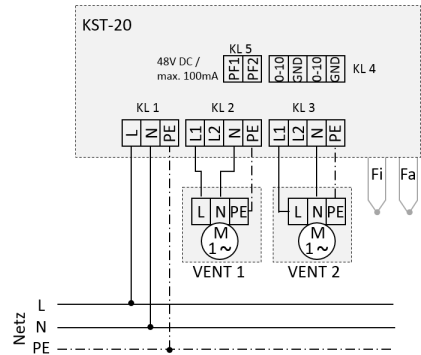

1-stage fans & Window opener (F)

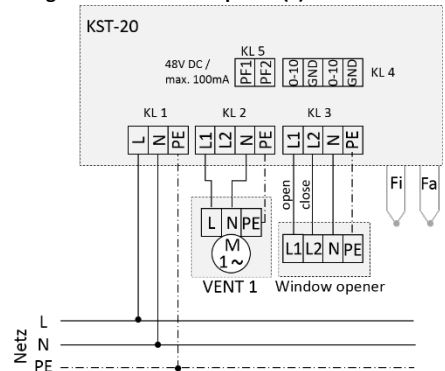

1-stage fan and Condensation dryer

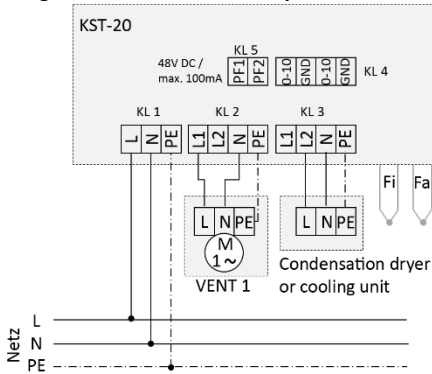

two 2-stage fans

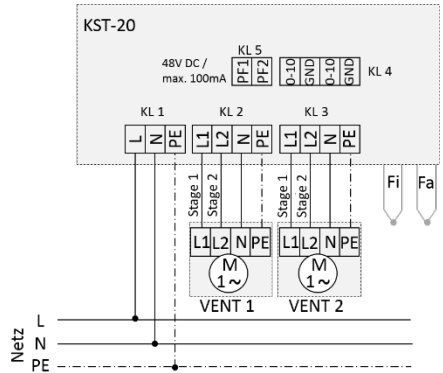

two speed-controlled fans

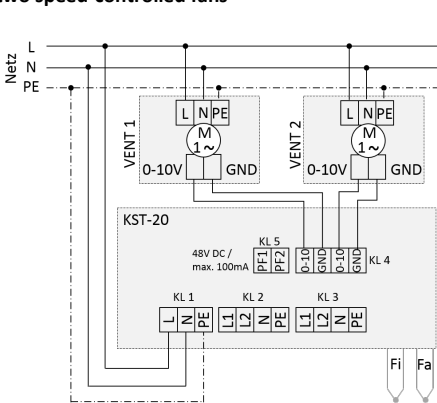

1 speed-controlled fan and 1 Condensation dryer

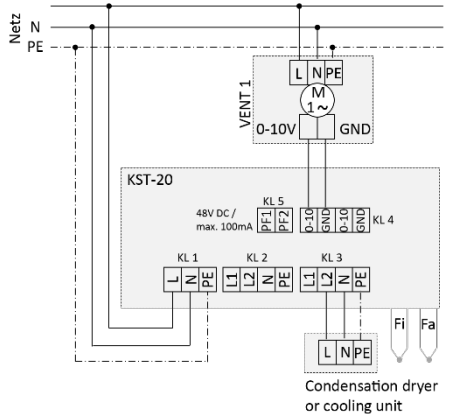

1 speed-controlled fan und 1 window opener

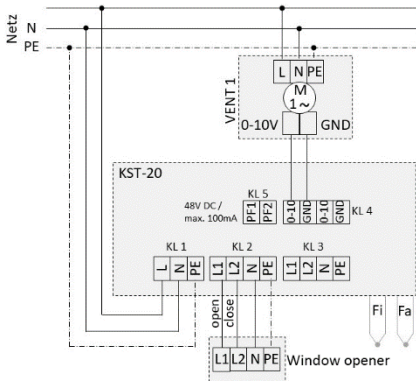

8. additions to the KST-20 Vento/CO2

The monitoring of CO2 and the climate values only takes place in the operating mode "ventilation".



8.1. actuators

2-stage or speed-controlled fans can be used as actuators.

If 2-stage fans are connected, the control is regulated like:

- Stage 1 (basic ventilation) as soon as the unit is switched on
- Stage 2, if CO2 limit value is exceeded or at absolute humidity outside less than inside

With speed-controlled fans, the fan runs at the set minimum speed DZMIN until the CO2 limit value is reached. The speed increases linearly up to the set maximum speed DZMAX depending on the CO2 value. The upper limit for CO2 is set at 3000 ppm.

The speed also changes climate-controlled, whereby CO2 has priority.

8.2. CO2- Measurement

The device also has a CO2 sensor for monitoring the air quality.

If the CO2 concentration in the room is below the set limit value, there is no control according to CO2, i.e. climate control is carried out (aH controlled).

As soon as the CO2 limit is exceeded, the respective control outputs are activated regardless of the climate values.

The current CO2 measured value can be displayed at any time using the PAUSE key (note: the control outputs also switch off in this case)

8.3. Connection of the sensors

The KST-20 Vento/CO2 is equipped with three connection sockets for the sensors. The indoor climate sensor is connected to the upper left beech. The outdoor climate sensor is connected to the upper right socket. The lower, central socket is intended for connecting the CO2 sensor.

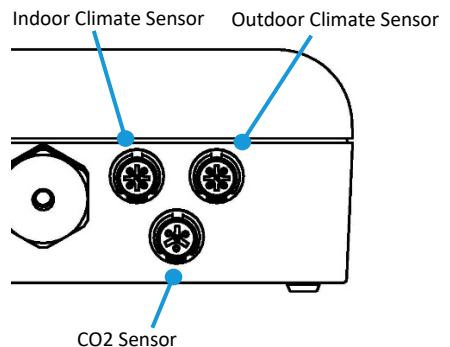

9. additions to the KST-20 Vento /RN



The monitoring of radon and the climate values only takes place in the operating mode "dehumidification".



9.1. actuators

1-stage, 2-stage or speed-controlled fans, window openers as well as heating registers in combination with speed-controlled fans can be used as actuators.

If 2-stage fans are connected, the control is regulated like:

- Stage 1 as soon as the limit value is exceeded.
- Step 2, if the value is 50 % above the set limit value

With speed-controlled fans, the fan starts at the set minimum speed DZMIN when the Radon limit value is reached. The speed increases linearly up to the set maximum speed DZMAX. DZMAX is reached when the Radon value is 50% above the set Radon limit value.

9.2. Radon measurement

The device has an additional radon sensor for monitoring the radon concentration.

If the radon concentration in the room is below the set limit value, there is no regulation according to radon, i.e. the regulation is climate controlled (aH controlled).

As soon as the radon limit is exceeded, the respective control outputs are activated regardless

of the climate values. The current Radon value is shown on the display.

9.3. Connection of the sensors

The KST-20 Vento/RN is equipped with three connection sockets for the sensors. The indoor climate sensor is connected to the upper left beech. The outdoor climate sensor is connected to the upper right socket. The radon sensor is connected to the lower middle socket.

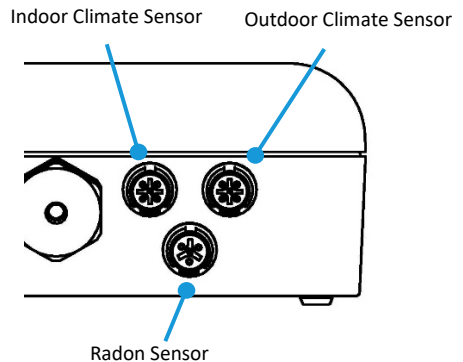

In case of a Radon sensor error, the display shows "Sensor error". The climate control system then continues to ventilate at the set interval.

10. device support

Phone: +49 (0) 3681 86 73 00

E-Mail: support@zila.de

Manufacturer of the device

ZILA GmbH

Neuer Friedberg 5

98527 Suhl

Phone: +49 (0) 3681 867300

Fax: +49 (0) 03681 8673099

Web: www.zila.de

e-Mail: info@zila.de