

### General

The cIO-CAN-50 is a low-cost CANopen module with 2 input and 2 output lines matching 24 V DC applications. The I/O are high side switching, and isolated from power supply and the CAN bus sub system.

The input lines provide special functionality for counting pulses and events, as well as measuring of period and duty-cycle.

The output lines provide PWM and are short-circuit protected.

CANopen is available according to DS301 and DS401. All usual baud rates up to 1 Mbit/s supported.



### Features

- Separate power supply for system/bus and I/O
- 2 digital inputs, isolated, high side switching
- 2 digital outputs isolated, high side switching, +24 VDC/+0.5 A, PWM suitable
- Special features:
  - IN0: Event counter (0...100,000 Hz) period measurement (0.5...0.0001 s)
  - IN1: signal measurement: period, duty-cycle
- Plastic housing for mounting onto DIN carrier rails
- Operating temperature 0...+55 °C (opt. -40...+70 °C)

### CANopen Features

- CAN baud rates up to 1 Mbit/s
- CAN bus ISO11898 with Transceiver TJA1050
- 4 Transmit- and 4 Receive-PDO
- Dynamic PDO Mapping
- Variable PDO Identifier
- CANopen PDO transfer modes: synchronous, asynchronous, event triggered, cyclic, acyclic and RTR
- Event Timer and Inhibit Timer for all Transmit-PDO
- Node-Guarding, Lifeguarding und Heartbeat
- Emergency messages
- Minimum Boot-Up

### Ordering information

Part	Order number
cIO-CAN-50	4000-1-0001
2/2 digital I/O, CAN isolated, 0...+55 °C	
cIO-CAN-50e	4000-1-0002
2/2 digital I/O, CAN isolated, -40...+70 °C	

## Technical data

Separate power supply for system/bus and I/O.

Power supply System	Min.	Norm.	Max.
Supply voltage System/Bus	+11VDC	+24 V DC	+32 V DC
Current consumption System/Bus	+20 mA (at V <sub>CC</sub> = +32 V DC)	+30 mA	+60 mA (at V <sub>CC</sub> = +11VDC)
Supply voltage I/O	+11VDC	+24VDC	+32 V DC
CAN bus Norm	ISO11898		
CiA Draft Standards	DS301 Version 4.0 and DS401 Version 2.0		
Conformance declaration	CE		
MTBF	5,287,408 hrs		

Digital inputs	
Number of inputs	2
Signal level LOW	< +8.1VDC
Signal level HIGH	> +8.2V DC
Min. HIGH-Time for signal measurement	10 µs
Min. LOW-Time for signal measurement	10 µs
Max. frequency pulse counting	250 kHz
Delay (CAN reaction time)	typ. 1 ms
Input current at 24 V DC	approx. +5 mA
Isolation from System/Bus	100V

Digital Outputs	
Number of outputs	2
Switching character	High-side switching
Protection	Short-circuitproof
Isolation from System/Bus	100V
Signal-Rise-Time (0...70 %)	Typ. 1 µs [load: 100 ohm]
Signal-Fall-Time (100...30 %)	Typ. 3 µs [load: 100 ohm]
PWM frequency range	1...24,000 Hz
PWM resolution	10...65,535 steps
Delay (CAN reaction time)	typ. 1 ms
Loads	resistive, inductive, lamps
Max. output current continuous	+0.5 A
Peak output current	+1.0 A max. 1s

Connectors and dimensions	
Connectors	Screw clamps
Cable cross-section [mm <sup>2</sup> ]	0.08...1.5 mm <sup>2</sup> (massive/flexible)
Cable cross-section [AWG]	26...14 AWG (massive/flexible)
Stripping length	8 mm
Dimensions housing	approx. 17.8 x 90 x 62 mm (see picture "dimensions"!) )
Operating temperature	0...+55 °C (optional -40...+70 °C)

**Connectors assignment**

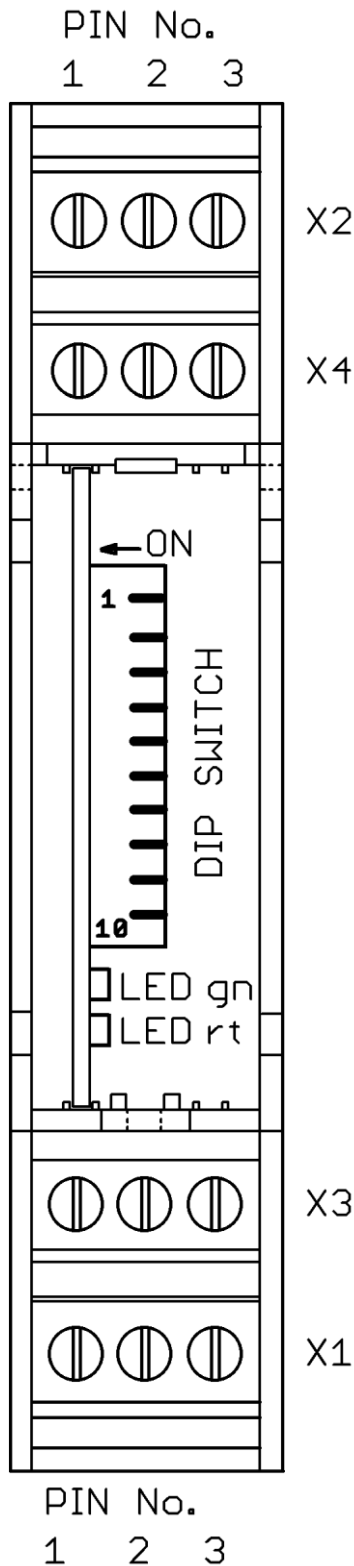

**Connector X1 (power)**

Pin-No.	Name	Description
1	U	+24VDC
2	GND	Ground
3	G1	Ground outputs

**Connector X2 (CAN)**

Pin-No.	Name	Description
1	L0	CANLow
2	H0	CAN High
3	G0	Ground

**Connector X3 (digital outputs)**

Pin-No.	Name	Description
1	O0	Output 0.0
2	O1	Output 0.1
3	P1	Power outputs

**Connector X4 (digital inputs)**

Pin-No.	Name	Description
1	I0	Input 0.0
2	I1	Input 0.1
3	G2	Ground inputs

## Wiring diagram

### Single supply

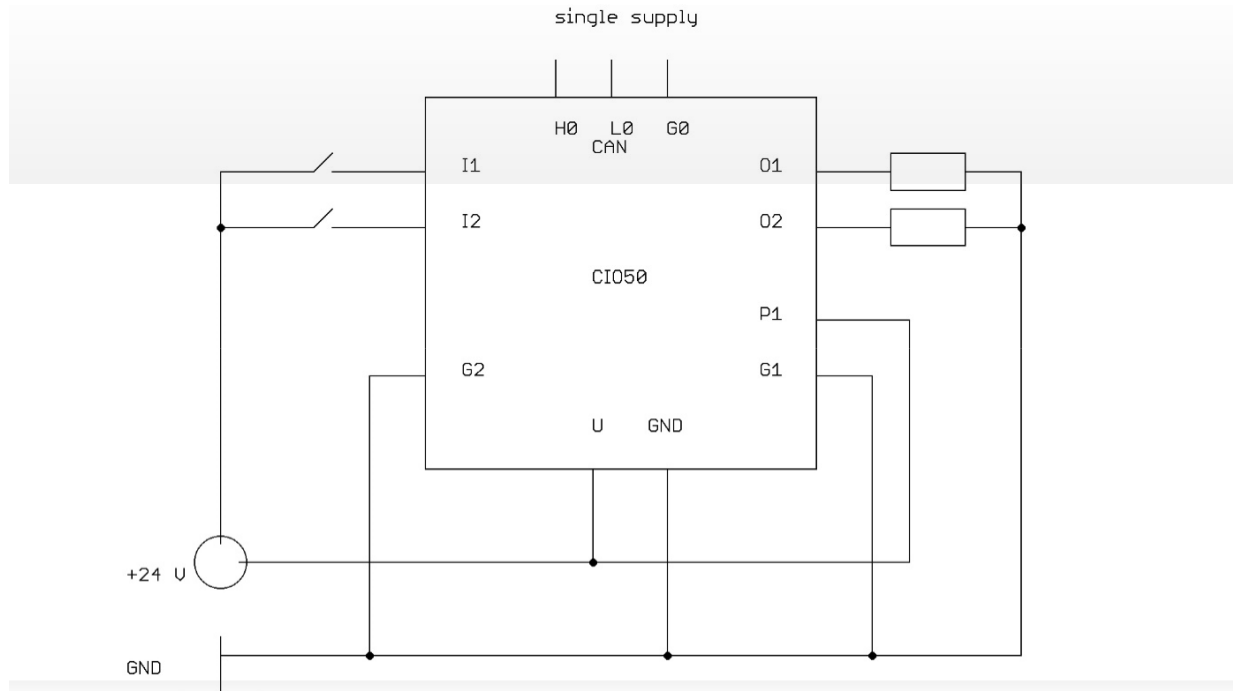

### Dual supply

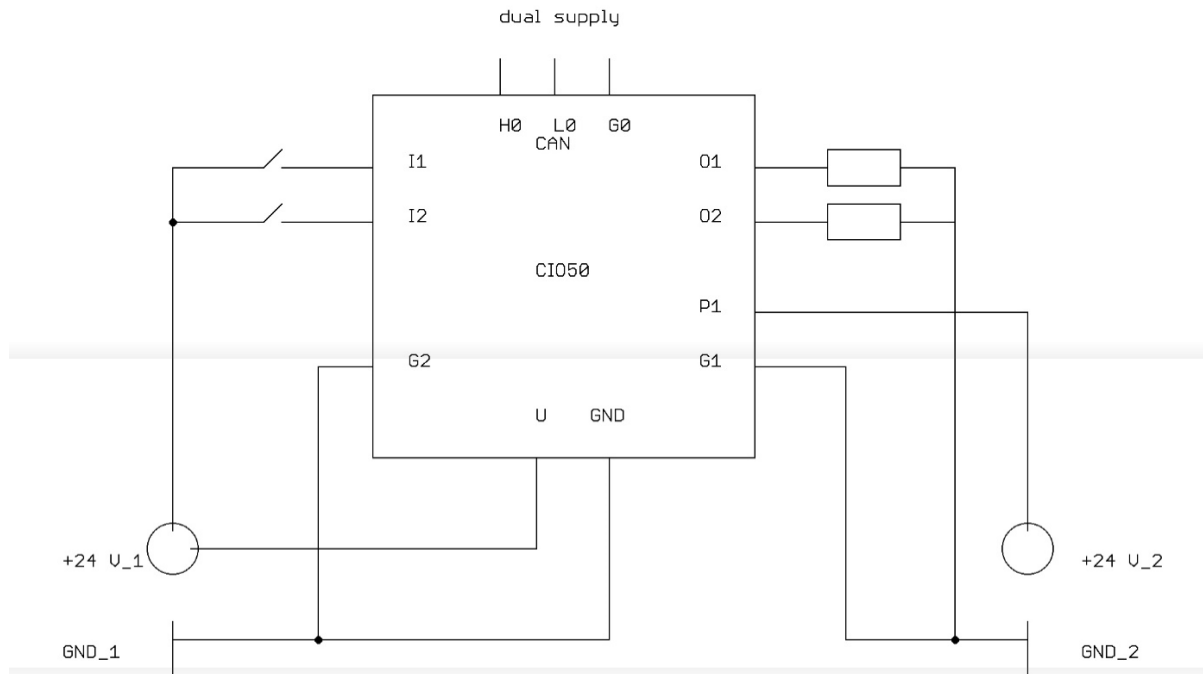

Dual supply (continuation)

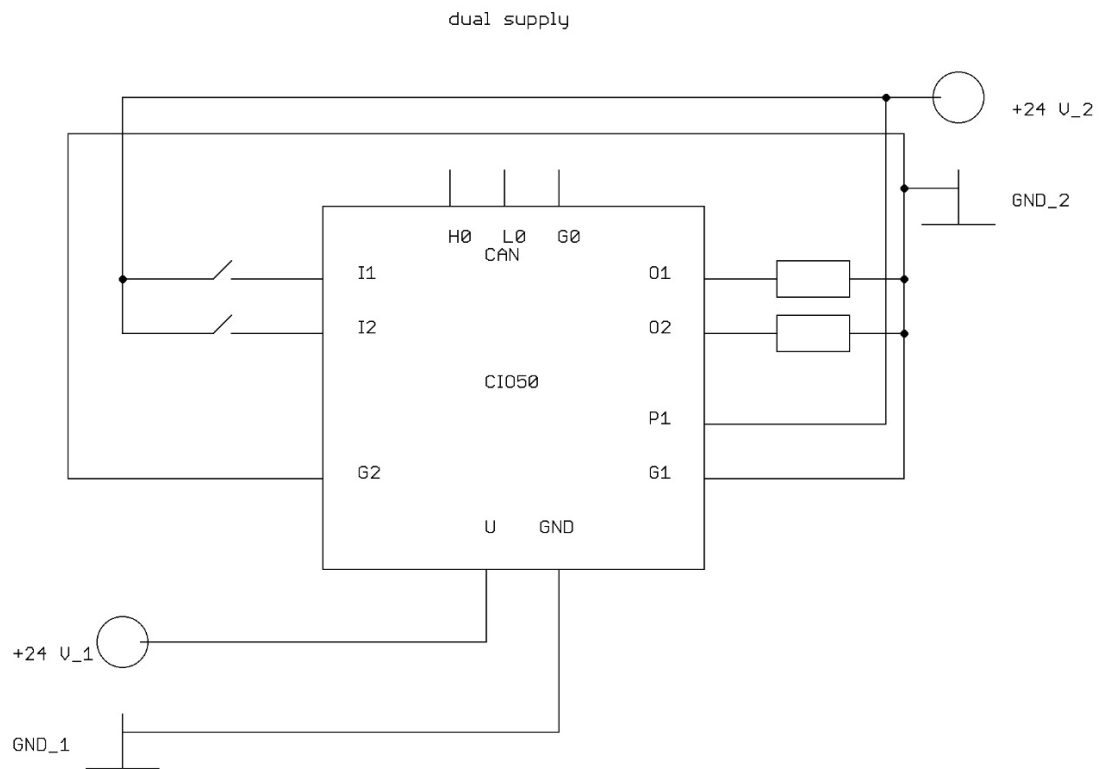
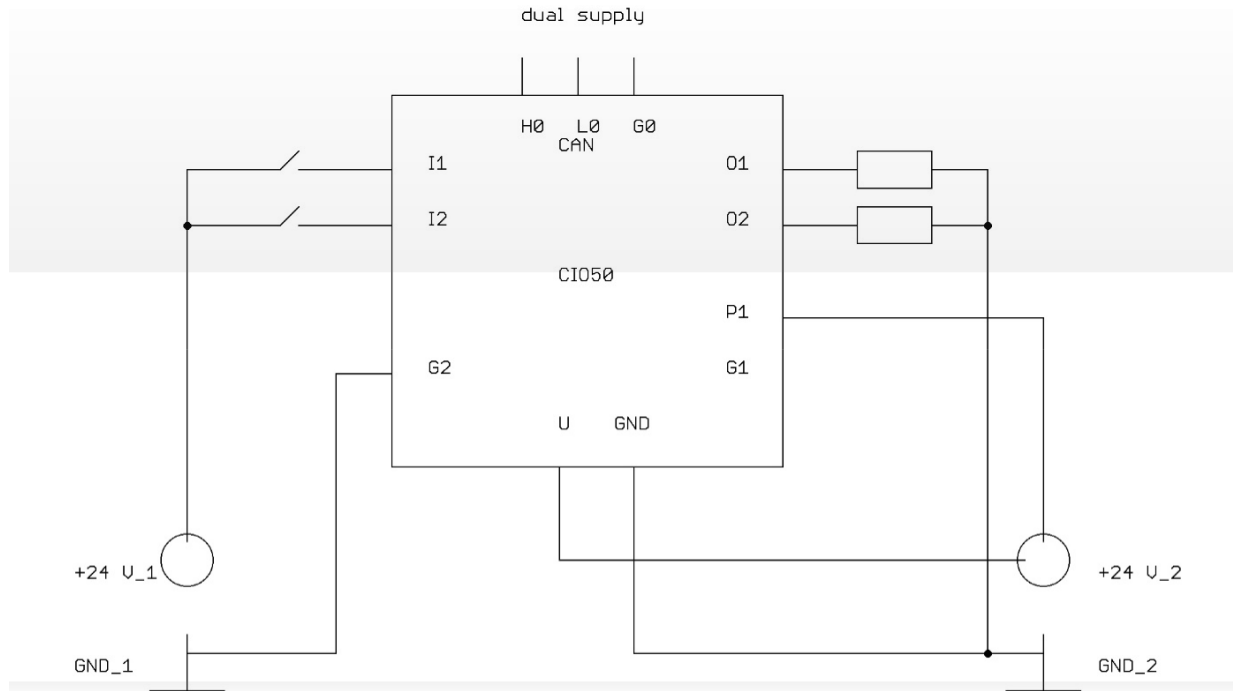

## Triple supply

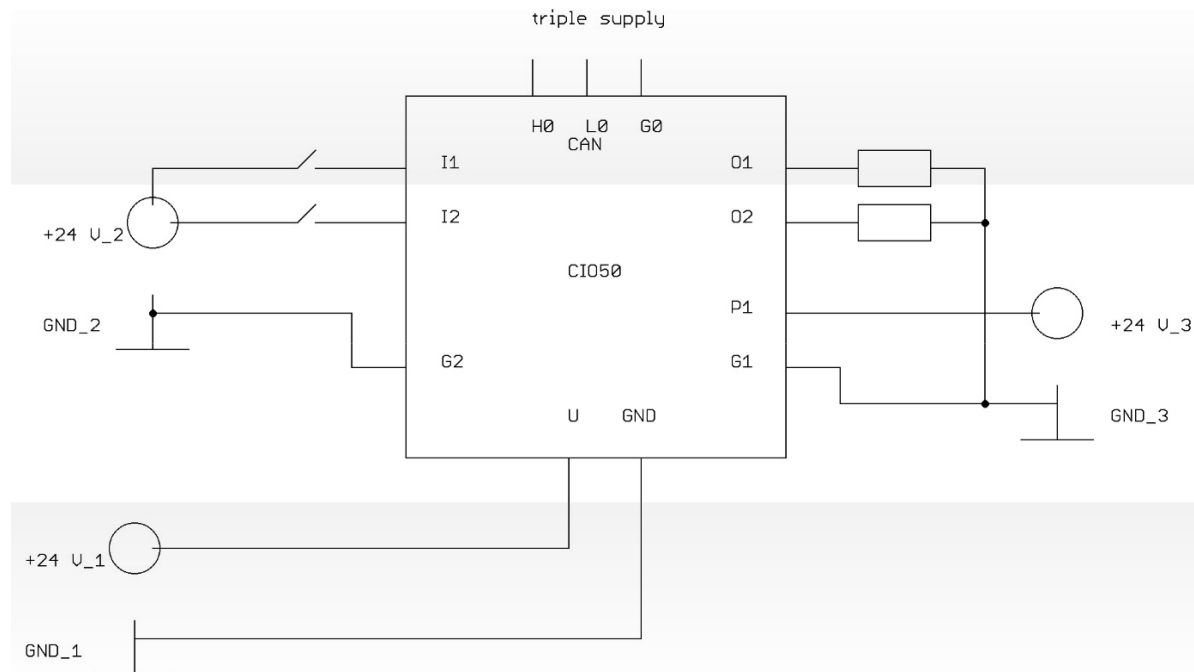

## Configuration Dip-Switch

Configuration of node-ID, baud rate and termination via DIP-Switch.  
The switches are inside the housing (open lid).

Switch Number										Description
1	2	3	4	5	6	7	8	9	10	
RT										RT Termination CAN-Bus
	BD2	BD1	BD0							BDx Baud rate CAN-Bus
				ID5	ID4	ID3	ID2	ID1	ID0	IDx Select Node-ID
ON										CAN-Termination on (120 Ohm)
OFF										CAN-Termination off
	OFF	OFF	OFF							1 MBit/s
	OFF	OFF	ON							800 kBit/s
	OFF	ON	OFF							500 kBit/s
	OFF	ON	ON							250 kBit/s
	ON	OFF	OFF							125 kBit/s
	ON	OFF	ON							50 kBit/s
	ON	ON	OFF							20 kBit/s
	ON	ON	ON							Reserved
				OFF	OFF	OFF	OFF	OFF	OFF	Reserved
				OFF	OFF	OFF	OFF	OFF	ON	Node-ID = 1
				OFF	OFF	OFF	OFF	ON	OFF	Node-ID = 2
				OFF	OFF	OFF	OFF	ON	ON	Node-ID = 3
				...	...	...	...	...	...	...
				ON	ON	ON	ON	OFF	OFF	Node-ID = 60
				ON	ON	ON	ON	OFF	ON	Node-ID = 61
				ON	ON	ON	ON	ON	OFF	Node-ID = 62
				ON	ON	ON	ON	ON	ON	Node-ID = 63

## CAN Signal-LED

The LED are located behind the lid. States are coded according to DRP303-3.

LED	Farbe	Funktion
RUN-LED	green	off no supply or faulty flickering CAN not started flashing Stopped blinking Preoperational on Operational
ERR-LED	red	Off no error 1x flashing CAN module in Error Warning State 2x flashing Node-Guarding error on Bus-Off

**Dimensions**

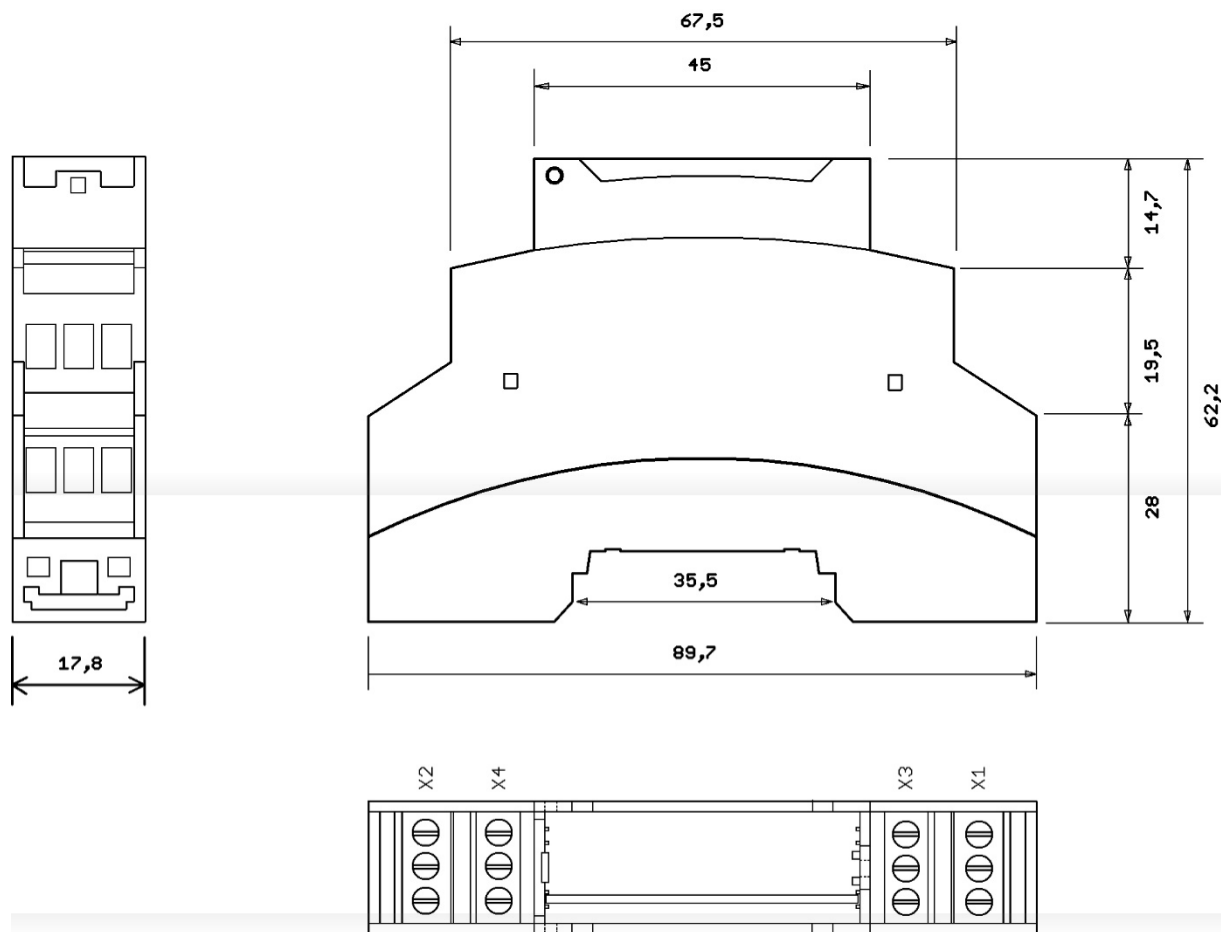

All measurements in millimeter (mm)



## CANopen Object Dictionary

### DS301: global objects

Index	Sub-Index	Name	Access
0005	-	Dummy 8	r/o
0006	-	Dummy 16	r/o
0007	-	Dummy32	r/o
1000	-	DeviceType	r/o
1001	-	Error Register	r/o
1002	-	Manufacturer Status Register	r/o
1005	-	COB-ID SYNC	r/o
1008	-	Device Name	r/o
1009	-	Hardware Version	r/o
100A	-	Software Version	r/o
100C	-	Guard Time	r/w
100D	-	Life Time Factor	r/w
100E	-	COB-ID Guard	-
1014	-	COB ID Emergency	r/w
1015	-	Inhibit Time Emergency	r/w
1016	0	Consumer Heartbeat Time	r/o
	1	Consumer Heartbeat Time 1	r/w
	2	Consumer Heartbeat Time 2	r/w
	3	Consumer Heartbeat Time 3	r/w
	4	Consumer Heartbeat Time 4	r/w
1017	-	Producer Heartbeat Time	r/w
1029		Error Behavior Object	r/o
	1	Communication error	r/w
	2	Application error	r/w

All index values are hexadecimal. Values in tables are hexadecimal (0x...) or decimal.

r/o read only  
w/o write only  
r/w read and write

All visible string data types are 20 characters at max.

**DS301: PDO Parameter objects**

Description of PDO Parameter. With these indexes, dynamic PDO-Mapping, free selection of IDs, transmission type, inhibit and event time is possible. These settings are selectable in "operational" as well as "preoperational" mode.

Index	Sub-Index	Name	Access
1400	0	Receive-PDO1 Communication Parameter	r/o
	1	COB-ID	r/w
	2	Transmission Type	r/w
1401...1403		Receive-PDO2 to RPDO4 Communication Parameter same as 1400	r/w
1600	0	Receive-PDO1 Parameter mapping	r/w
	1 to n	Mapped objects (max. 8 objects mappable)	r/w
1601...1603		Receive-PDO2 to RPDO4 Parameter mapping same as 1600	r/w
1800	0	Transmit-PDO1 Communication Parameter	r/o
	1	COB-ID	r/w
	2	Transmission Type	r/w
	3	Inhibit Time	r/w
	4	Reserved	r/w
	5	Event Time	r/w
1801...1803		Transmit-PDO2 to TPDO4 Communication Parameter same as 1800	r/w
1A00	0	Transmit-PDO1 Parameter mapping	r/w
	1 to n	Mapped objects (max. 8 objects mappable)	r/w
1A01...1A03		Transmit-PDO2 to TPDO4 Parameter mapping same as 1A00	r/w

**Specific objects**

Index	Sub-Index	Name	Access
2009	0	Serial Number 64 Bit	r/o
	1	Serial Number 64 Bit LSDW	r/o
	2	Serial Number 64 Bit MSDW	r/o
2101	-	System Configuration	r/o
2102	-	Remapping Enabled Info	r/o
2103	-	Enable Guarding Warning	r/w
2105	-	Internal API State	r/o
2110	0	Conformance Test Object	r/o
	1	Range Check Object	r/w
2180	-	CAN Restart Time	r/w

**DS401: digital inputs**

Index	Sub-Index	Name	Access
6000	0 to n	Read digital input 8 bit	r/o
6002	0 to n	Polarity input 8 bit	r/w
6005	-	Global Interrupt Enable	r/w
6006	0 to n	Interrupt Mask Any Change	r/w
6007	0 to n	Interrupt Mask Rising Edge	r/w
6008	0 to n	Interrupt Mask Falling Edge	r/w
6100	0 to n	Read Digital Input 16 Bit	r/o
6120	0 to n	Read Digital Input 32 Bit	r/o

**DS401: digital outputs**

Index	Sub-Index	Name	Access
5200	-	Reset Output Object on Error	r/w
6200	0 to n	Write Output 8 Bit	r/w
6206	0 to n	Error Mode Output	r/w
6207	0 to n	Error State Output	r/w
6300	0 to n	Write Digital Output 16 Bit	w/o
6320	0 to n	Write Digital Output 32 Bit	w/o

**Product related specific objects sorted by function**

Index	Sub-Index	Name	Access
4000	-	Counter Value for IN0	r/o
4001	-	Counter Control for IN0	r/w
4008	-	Counter Mode for IN0	r/w

**Counter**

Index	Sub-Index	Name	Access
4100	-	IN0 Period	r/o
4107	-	IN0 Pulse Measuring Enable	r/w
4110	-	IN1 Period	r/o
4111	-	IN1 High Time	r/o
4112	-	IN1 Low Time	r/o
4117	-	IN1 Pulse Measuring Enable	r/w

**Pulse  
measuring**

Index	Sub-Index	Name	Access
5100	0 to n	Output PWM Value	r/w
5101	0 to n	Output PWM Control	r/w
5102	0 to n	Output PWM Steps	r/w
5107	-	Output PWM Prescaler	r/w

**PWM**

## Object dictionary (description)

Following comes a short description of every dictionary entry.

### DS301: Global objects

#### Index 0005

Dummy for spaces in PDO mapping (8-bit length).  
Can be used, more than once.

Index	0005
Name	Dummy 8
Description	
Data Type	Unsigned 8
Access	r/o
PDO Mapping	Yes
Value Range	-
Default Value	0

#### Index 0006

Dummy for spaces in PDO mapping (16-bit length).  
Can be used, more than once.

Index	0006
Name	Dummy 16
Description	
Data Type	Unsigned 16
Access	r/o
PDO Mapping	Yes
Value Range	-
Default Value	0

#### Index 0007

Dummy for spaces in PDO mapping (32-bit length).  
Can be used, more than once.

Index	0007
Name	Dummy 32
Description	
Data Type	Unsigned 32
Access	r/o
PDO Mapping	Yes
Value Range	-
Default Value	0

**Index 1000: Device Type**

This index contains a description of the device type. Within are encoded the CiA profile code and additional specifications of the device.

Index	1000
Name	Device Type
Description	-
Data Type	Unsigned 32
Access	r/o
PDOMapping	No
Value Range	-
Default Value	0x0083 0191

**Index 1001: Error Register**

This index contains the internal error code in case of emergency.

Index	1001
Name	Error Register
Description	-
Data Type	Unsigned 8
Access	r/o
PDOMapping	Yes
Value Range	-
Default Value	-

The error register is built as shown. If more than one error occur, the values are combined via logical OR.

Bit	Description
0	Common error. This bit is set with every error.
1	0
2	0
3	0
4	CAN bus or communication error
5	0
6	0
7	Device error

**Index 1002: Status Register**

This index contains additional status information of the device.

Index	1002
Name	Status Register
Description	-
Data Type	Unsigned 32
Access	r/o
PDOMapping	Yes
Value Range	-
Default Value	-

**Index 1005: COB-ID SYNC**

This index sets the COB-ID for SYNC messages.

This device is a receiving device. SYNC production is not supported.

Index	1005
Name	COB-ID Sync
Description	-
Data Type	Unsigned 32
Access	r/w
PDO Mapping	No
Value Range	1...0x7FF
Default Value	0x80

**Index 1008: Device Name**

This index contains the device name as a visible string.

<sup>1)</sup> xxx: Number of the product

Index	1008
Name	Device Name
Description	-
Data Type	Visible String
Access	r/o
PDO Mapping	No
Value Range	The maximum string length is 20 characters
Default Value	"hipecs-CIOxxx <sup>1)</sup> "

**Index 1009: Hardware Version**

This index contains the revision code of the hardware as visible string.

Index	1009
Name	Hardware Version
Description	-
Data Type	Visible String
Access	r/o
PDO Mapping	No
Value Range	The maximum string length is 20 characters
Default Value	-

**Index 100A: Software Version**

This index contains the firmware version as visible string.

Index	100A
Name	Software Version
Description	-
Data Type	Visible String
Access	r/o
PDO Mapping	No
Value Range	The maximum string length is 20 characters
Default Value	-



**Index 100C: Guard Time**

Together with index 100D, this index represents the lifeguarding protocol. Values are in milliseconds.

Guard Time multiplied by Life Time Factor results in Life Time.

Set up 0 (zero), if not used.

Index	100C
Name	Guard Time
Description	-
Data Type	Unsigned 16
Access	r/w
PDOMapping	No
Value Range	
Default Value	0

**Index 100D: Life Time Factor**

Together with index 100C, this index represents the lifeguarding protocol. Values are factors.

Guard Time multiplied by Life Time Factor results in Life Time.

Set up with 0 (zero), if not used.

Index	100D
Name	Life Time Factor
Description	-
Data Type	Unsigned 8
Access	r/w
PDOMapping	No
Value Range	
Default Value	0

**Index 100E: COB-ID Guard**

This index contains the ID for guarding protocol.

Index	100E
Name	COB-ID Guard
Description	-
Data Type	Unsigned 32
Access	-
PDOMapping	No
Value Range	-
Default Value	0x700 + Node-ID

**Index 1014: COB-ID Emergency**

This index sets the ID for emergency messages.

Index	1014
Name	COB-ID Emergency
Description	-
Data Type	Unsigned 32
Access	r/w
PDOMapping	No
Value Range	-
Default Value	0x80 + Node-ID

**Index 1015: Inhibit Time Emergency**

This index sets up a delay for transmitting any emergency. This device supports a delay with an interval of one millisecond.

Index	1015
Name	Inhibit Time Emergency
Description	-
Data Type	Unsigned 16
Access	r/w
PDOMapping	No
Value Range	-
Default Value	0 (disabled)

**Index 1016: Consumer Heartbeat Time**

Index 1016 is used to monitor the Heartbeat Consuming of up to four nodes.

Index	1016
Name	Consumer Heartbeat Time
Description	-
Data Type	Structure

**Attention:**

Heartbeat monitoring starts with the reception of the first heartbeat.  
The Producer Time should be greater than the Consumer Time.  
Ahead of the first heartbeat, the Producers status is unknown.

Index	1016.00
Name	Number of indexes supported
Description	-
Data Type	Unsigned 8
Access	r/o
PDOMapping	No
Value Range	-
Default Value	4

**Structure of the Consumer Heartbeat Time**

MSB		LSB	
Byte3	Byte2	Byte1	Byte0
Reserved	Node-ID	Heartbeat time	

Index	1016.01...1016.04
Name	Consumer Heartbeat Time 1...4
Description	-
Data Type	Unsigned 32
Access	r/w
PDOMapping	No
Value Range	-
Default Value	0

**Index 1017: Producer Heartbeat Time**

This index sets up the heartbeat cycle in an interval of one millisecond.  
If it is not used, set up 0 (zero).

**Attention:**

Use either Heartbeat or Node-Guarding. Both at once is not allowed.

Index	1017
Name	Producer Heartbeat Time
Description	-
Data Type	Unsigned 16
Access	r/w
PDOMapping	No
Value Range	-
Default Value	0

**Index 1029: Error Behavior**

This index sets up whether the device switches its operating state in case of emergency, or not. Possible changes are Pre-Operational or Stopped. No change at all and keeping the current state is possible, too.

Index	1029
Name	Error Behavior Object
Description	-
Data Type	Structure

As communication error counts, e.g., Bus-Off, Heartbeat, Guarding or internal errors of the device.

Index	1029.00
Name	Number of indexes supported
Description	-
Data Type	Unsigned char
Access	r/o
PDOMapping	No
Value Range	-
Default Value	2

The values of the states are as follows:

- 0 Pre-Operational (only if Operational)
- 1 no change
- 2 Stopped
- 3..255 reserved

Index	1029.01
Name	Communication Error
Description	NMT state change in case of communication error
Data Type	Unsigned 8
Access	r/w
PDOMapping	No
Value Range	-
Default Value	0

Index	1029.02
Name	Application Error
Description	NMT state change in case of internal error due to hardware malfunction
Data Type	Unsigned 8
Access	r/w
PDOMapping	No
Value Range	-
Default Value	0

## DS301: PDO Parameter Objects

### Communication Parameter Objects

The transmission type for Transmit- and Receive-PDO are set up with sub-index 2.

Type	PDO transmission				
	cyclic	acyclic	synchronous	asynchronous	RTR
0		X	X		
1-240	X		X		
241-251	Reserved				
252			X		X
253				X	X
254				X	
255				X	

The synchronous transmission types 0...240 and 252 are dependent on the SYNC signal. Asynchronous transmission is independent from the SYNC.

Type 0 is triggered by the SYNC, however, a transmission is only made, if the PDO data changes.

A value between 1 and 240 says the transmission is synchronous and cyclic. The transmission type represents the needed number of SYNCs for triggering the PDO.

Type 252 triggers a transmission with the next available SYNC, but only if a RTR releases the PDO. Type

253 transmits the PDO immediately, however, only on RTR.

With type 254 and 255, the manufacturer or the device profile set the conditions.

An inhibit time can be set in sub-index 3. The PDO are triggered by their conditions, but only transmitted if the inhibit time is up. This time is set as a multiple of 100 µs, a value of 0 (zero) renders the function useless.

In mode 254/255, an additional Event Time is set. This timer running out is considered an event. The time is set as a multiple of 1 ms. This event triggers a PDO transmission in addition to other possible events.

Index 1400 is an example for Receive-PDO and index 1800 is an example for Transmit-PDO.

Index	PDO
1400...14xx	Receive-PDO1...Receive-PDOxx
1800...18xx	Transmit-PDO1...Transmit-PDOxx

Index	14xx/18xx
Name	Receive-/Transmit-PDOx Communication Parameters
Description	-
Data Type	Structure

Index	14xx.00/18xx.00
Name	Number of indexes supported
Description	-
Data Type	Unsigned 8
Access	r/o
PDOMapping	No
Value Range	-
Default Value	2/5

1400.01	ID + 200	1800.01	ID + 180
1401.01	ID + 80000300	1801.01	ID + 80000280
1402.01	ID + 80000400	1802.01	ID + 80000380
1403.01	ID + 80000500	1803.01	ID + 80000480

The table shows the default PDO-ID values.  
An Identifier von 8xxxxxxx means the PDO is rendered inactive. The CAN master has to assign a valid PDO-ID.

See table on top of the chapter.

Multiple of 1 µs.

Multiple of 1 ms.

Index	14xx.01/18xx.01
Name	COB-ID
Description	Identifier for CAN-Object for PDO
Data Type	Unsigned 32
Access	r/w
PDOMapping	No
Value Range	-
Default Value	

Index	14xx.02/18xx.02
Name	Transmission Type
Description	-
Data Type	Unsigned 8
Access	r/w
PDOMapping	No
Value Range	-
Default Value	0xFF

Index	18xx.03
Name	Inhibit Time
Description	-
Data Type	Unsigned 16
Access	r/w
PDOMapping	No
Value Range	-
Default Value	0

Index	18xx.04
Name	Reserved
Description	-
Data Type	-
Access	-
PDOMapping	No
Value Range	-
Default Value	-

Index	18xx.05
Name	Event Time
Description	-
Data Type	Unsigned 16
Access	r/w
PDOMapping	No
Value Range	-
Default Value	0

**PDO mapping objects**

The following table shows the PDO mapping entries. This is the same for all PDO. The mapping table is a linking index for entries of the object dictionary (e.g. data of digital outputs) and position in the PDO.

Sub-Index 0 gives the number of valid entries. The cIO-CAN-50 supports up to eight entries each PDO. In order to change the mapping, sub-index 0 has to be set to 0 (zero) first (inactive). Now the entries can be altered. If a new entry is mapped, the cIO-CAN-50 checks whether the entry is valid or not. Invalid entries result in an abort.

All eight sub-indexes are pointer to the entries. A value of 0 (zero) means no entry. The pointer's structure is:

MSB		LSB	
Byte3	Byte2	Byte1	Byte0
mapped index		sub-index	Length

Index and sub-index combined are the pointer; Length is the data length of the pointer's target in bit.

Index	160x/1A0x
Name	Receive-/Transmit-PDO Mapping Parameters
Description	-
Data Type	Array

Index	160x/1A0x.00
Name	Number of indexes supported
Description	Number of mapped objects
Data Type	Unsigned 8
Access	r/w
PDO Mapping	No
Value Range	-
Default Value	See table below

Index	160x/1A0x.01...160x/1A0x.08
Name	Mapped object
Description	
Data Type	Unsigned 32
Access	r/w
PDO Mapping	No
Value Range	-
Default Value	See table below

**Receive-PDO**

The cIO-CAN-50 uses this default configuration for Receive-PDO.

Index	Entry	
Receive-PDO1		
1600.00	1	
1600.01	62000108	Digital output 0.0...0.1
Receive-PDO2		
1601.00	1	
1601.01	40010010	Counter Control IN0
Receive-PDO3		
1602.00	2	
1602.01	51000110	Output PWM Value 1
1602.02	51000210	Output PWM Value 2
Receive-PDO4		
1603.00	0	

**Transmit-PDO**

The cIO-CAN-50 uses this default configuration for Transmit-PDO.

Index	Entry	
Transmit-PDO1		
1A00.00	1	
1A00.01	60000108	Digital input 0.0...0.1
Transmit-PDO2		
1A01.00	1	
1A01.01	40000020	Counter Value IN0
Transmit-PDO3		
1A02.00	1	
1A02.01	41000020	IN0 Signal Period
Transmit-PDO4		
1A03.00	2	
1A03.01	41100020	IN1 Signal Period
1A03.02	41110020	IN1 Signal High Time

## Specific Objects

### Index 2009: Serial Number 64 Bit

This index contains the serial number of this device.

Index	2009
Name	Serial Number 64 Bit
Description	-
Data Type	Array

Index	2009.00
Name	Number of indexes supported
Description	-
Data Type	Unsigned 8
Access	r/o
PDOMapping	No
Value Range	-
Default Value	2

Index	2009.01
Name	Serial Number Low Double Word
Description	Bits 0...31 of the serial number
Data Type	Unsigned 32
Access	r/o
PDOMapping	No
Value Range	-
Default Value	-

Index	2009.02
Name	Serial Number High Double Word
Description	Bits 32...63 of the serial number
Data Type	Unsigned 32
Access	r/o
PDOMapping	No
Value Range	-
Default Value	-



**Index 2101: System Configuration**

This index shows the current operating mode of the device.

Index	2101
Name	System Configuration
Description	-
Data Type	Unsigned 32
Access	r/o
PDOMapping	No
Value Range	-
Default Value	0

**Index 2102: Remapping Enabled Info**

This index shows, whether remapping the PDO is allowed or prohibited.

0 = remapping prohibited  
1 = remapping allowed

Index	2102
Name	Remapping Enabled Info
Description	-
Data Type	Unsigned 8
Access	r/o
PDOMapping	No
Value Range	-
Default Value	1

**Index 2103: Enabled Guarding Warning**

This index enables an additional warning when Node-Guarding is used.

The CAN master is given an early report for an imminent Node-Guarding failure.  
The warning is triggered when the Guard Time is up (Index 100C).  
The NMT state remains unaffected.

Index	2103
Name	Enable Guarding Warning
Description	-
Data Type	Unsigned 8
Access	r/w
PDOMapping	No
Value Range	-
Default Value	0

**Index 2105: Internal Error Code**

These are internal error messages of the CANopen controller.

Index	2105
Name	Internal Error Code
Description	-
Data Type	Unsigned 32
Access	r/o
PDOMapping	Yes
Value Range	-
Default Value	0 (no error condition)

**Index 2110: Test Object**

This index is for internal test purposes only. It possesses no function and is not to use.

Index	2110
Name	Test Object 01
Description	-
Data Type	Structure

Index	2110.00
Name	Number of indexes supported
Description	-
Data Type	Unsigned char
Access	r/o
PDOMapping	No
Value Range	-
Default Value	1

Index	2110.01
Name	Range Check Object
Description	-
Data Type	Unsigned 16
Access	r/w
PDOMapping	No
Value Range	100...1000
Default Value	500

**Index 2180: CAN Restart Time**

With this index, the restart time for the CAN communication in case of a Bus-Off error is defined. The value is set in milliseconds.

0 (zero) disables this function.

Index	2180
Name	CAN Restart Time
Description	-
Data Type	Unsigned 16
Access	r/w
PDOMapping	No
Value Range	0...50000
Default Value	1000 (restart after one second)

**DS401: digital inputs****Index 6000: Read Digital Input 8 Bit**

This index represents the values of the digital inputs.

Index	6000
Name	Digital Input 8 Bit
Description	-
Data Type	Array

Index	6000.00
Name	Number of indexes supported
Description	
Data Type	Unsigned 8
Access	r/o
PDO Mapping	No
Value Range	-
Default Value	-

Index	6000.01...6000.xx
Name	Digital Input 8 Bit
Description	
Data Type	Unsigned 8
Access	r/o
PDO Mapping	Yes
Value Range	-
Default Value	-

**Index 6100: Read Digital Input 16 Bit**

Same specifications as index 6000, only with 16-bit-access.

**Index 6120: Read Digital Input 32 Bit**

Same specifications as index 6000, only with 32-bit-access.

**Index 6002: Polarity Input 8 Bit**

With this index, the values of the digital inputs can be inverted.

Index	6002
Name	Polarity Input 8 Bit
Description	-
Data Type	Array

Index	6002.00
Name	Number of indexes supported
Description	
Data Type	Unsigned 8
Access	r/o
PDOMapping	No
Value Range	-
Default Value	-

Index	6002.01...6002.xx
Name	Polarity Input 8 Bit
Description	
Data Type	Unsigned 8
Access	r/w
PDOMapping	No
Value Range	-
Default Value	0

**Index 6005: Global Interrupt Enable**

This index enables a global interrupt without changing the setups of the interrupt masks. In event mode the values are transmitted depending on indexes 6006, 6007, 6008 und the transmission type.

TRUE (1) = interrupt enable FALSE  
(0) = interrupt disable

Index	6005
Name	Global Interrupt Enable
Description	-
Data Type	Boolean
Access	r/w
PDOMapping	No
Value Range	-
Default Value	TRUE

**Index 6006: Interrupt Mask Any Change**

This index gives whether an interrupt is created by any change. If enabled, both rising and falling edges are considered valid. Interrupts trigger PDO transmissions in event mode.

Index	6006
Name	Interrupt Mask any change
Description	-
Data Type	Array

Index	6006.00
Name	Number of indexes supported
Description	
Data Type	Unsigned 8
Access	r/o
PDOMapping	No
Value Range	-
Default Value	-

1 = Interrupt enable

0 = Interrupt disable

Index	6006.01...6006.xx
Name	Interrupt Mask any change
Description	
Data Type	Unsigned 8
Access	r/w
PDOMapping	No
Value Range	-
Default Value	0xFF (interrupt enabled)

**Index 6007: Interrupt Mask Low to High**

Same specifications as index 6006, but only rising edges are valid. Default is 0 (zero) (disabled).

**Index 6008: Interrupt Mask High to Low**

Same specifications as index 6006, but only falling edges are valid. Default is 0 (zero) (disabled).

## DS401: digital outputs

### Index 5200: Output Reset on Error Option

This index determines whether the outputs restore their original states after acknowledging and dealing with a critical error.

0 (zero) maintains the original states of index 6200.xx. In case of an error, the outputs are set according to indexes 6206 and 6207. After the error cleared, the states of index 6200.xx are restored.

1 and greater overwrites the outputs permanently. The original states are not restored, since index 6200.xx is overwritten with the safe-states of error handling.

Index	5200
Name	Output Reset on Error Option
Description	-
Data Type	Unsigned 8
Access	r/w
PDOMapping	No
Value Range	-
Default Value	1

### Index 6200: Write to Digital Output

With this index the digital outputs are set.

Index	6200
Name	Write to digital output
Description	-
Data Type	Array

Index	6200.00
Name	Number of indexes supported
Description	
Data Type	Unsigned 8
Access	r/o
PDOMapping	No
Value Range	-
Default Value	-

Index	6200.01...6200.xx
Name	Write to digital output
Description	
Data Type	Unsigned 8
Access	r/w
PDOMapping	Yes
Value Range	-
Default Value	0

### Index 6300: Write Digital Output 16 Bit

Same specifications as index 6200, only with 16-bit-access.

### Index 6320: Write Digital Output 32 Bit

Same specifications as index 6200, only with 32-bit-access.

**Index 6206: Error Mode Output 8 Bit**

With this is set, whether the outputs change to predefined states (index 6207) in case of an error.

Index	6206
Name	Error Mode Output 8 Bit
Description	-
Data Type	Array

Index	6206.00
Name	Number of indexes supported
Description	
Data Type	Unsigned 8
Access	r/o
PDOMapping	No
Value Range	-
Default Value	-

1 = output changes according to index 6207  
 0 = output does not change

Index	6206.01...6206.xx
Name	Error Mode Output 8 Bit
Description	
Data Type	Unsigned 8
Access	r/w
PDOMapping	No
Value Range	-
Default Value	0xFF

**Index 6207: Error Value Output 8 Bit**

With this index, the error states for the outputs are predefined.

Index	6207
Name	Error Value Output 8 Bit
Description	-
Data Type	Array

Index	6207.00
Name	Number of indexes supported
Description	
Data Type	Unsigned 8
Access	r/o
PDOMapping	No
Value Range	-
Default Value	-

0 = output disabled  
 1 = output enabled

Index	6207.01...6207.xx
Name	Error Value Output 8 Bit
Description	
Data Type	Unsigned 8
Access	r/w
PDOMapping	No
Value Range	-
Default Value	0 (Inactive, high level)

## Product related specific objects sorted by function

### Counter

#### Index 4000: Counter Value

This index shows the amount of ticks from the event counter on input IN0.0.

Index	4000
Name	Counter Value
Description	Counter Value for IN0
Data Type	Unsigned 32
Access	r/o
PDOMapping	Yes
Value Range	0...4.294.967.295
Default Value	0

#### Index 4001: Counter Control

This index controls the counter on IN0.

Bit 0 (enable) and bit 4 (reset) are the control switches.

Bit 0 = 0 (counter stopped)

Bit 0 = 1 (counter started)

Bit 4 = 0 (n.a.)

Bit 4 = 1 (counter reset)

Index	4001
Name	CounterControl
Description	Counter Control for IN0 Counter
Data Type	Unsigned 16
Access	r/w
PDOMapping	Yes
Value Range	-
Default Value	0 (disabled)

#### Index 4008: Counter Mode

Reserved!

Do not change!

Index	4008
Name	Counter Mode
Description	RESERVED
Data Type	Unsigned 16
Access	r/w
PDOMapping	No
Value Range	-
Default Value	0 (do not change)

#### Index 4100: IN0 Period

This index shows the period of IN0 measured in microseconds.

Attention:

This device supports only periods > 10 µs (f < 100 kHz)

Index	4100
Name	IN0 Period
Description	Measured IN0 Period
Data Type	Unsigned 32
Access	r/w
PDOMapping	Yes
Value Range	-
Default Value	0



## Pulse measurement

### Index 4107: IN0 Pulse Measuring Enable

This index activates the pulse measuring on IN0.  
Only measuring period is supported.

Only bit 0 (zero) is a control switch.

Bit 0 = 0 (measuring deactivated)

Bit 0 = 1 (measuring activated)

Index	4107
Name	IN0 Pulse Measuring Enable
Description	-
Data Type	Unsigned 8
Access	r/w
PDOMapping	No
Value Range	-
Default Value	0

### Index 4110: IN1 Period

This index shows the period of IN1 measured in microseconds.

Attention:

This device supports only  
periods > 10  $\mu$ s (f < 100 kHz)

Index	4110
Name	IN1 Period
Description	Measured IN1 Period
Data Type	Unsigned 32
Access	r/w
PDOMapping	Yes
Value Range	-
Default Value	0

### Index 4111: IN1 High Time

This index shows the pulse high time of IN1 in microseconds.

Index	4111
Name	IN1 High Time
Description	Measured IN1 high time
Data Type	Unsigned 32
Access	r/w
PDOMapping	Yes
Value Range	-
Default Value	0

**Index 4112: IN1 Low Time**

This index shows the pulse low time of IN1 in microseconds.

Index	4112
Name	IN1 Low Time
Description	Measured IN1 low time
Data Type	Unsigned 32
Access	r/w
PDOMapping	Yes
Value Range	-
Default Value	0

**Index 4117: IN1 Pulse Measuring Enable**

This index activates the pulse measuring on IN1. Measuring period and pulse high/low time are supported.

Only bit 0 (zero) is a control switch.

Bit 0 = 0 (measuring deactivated)

Bit 0 = 1 (measuring activated)

Index	4117
Name	IN1 Pulse Measuring Enable
Description	-
Data Type	Unsigned 8
Access	r/w
PDOMapping	No
Value Range	-
Default Value	0

**PWM****Index 5100: Output PWM Value**

This index sets the PWM value.

Index	5100
Name	Output PWM Value
Description	-
Data Type	Array

Index	5100.00
Name	Number of indexes supported
Description	-
Data Type	Unsigned 8
Access	r/o
PDOMapping	No
Value Range	-
Default Value	2

Setting of the duty-cycle.

Index	5100.01...5100.xx
Name	Output PWM Value
Description	
Data Type	Unsigned 16
Access	r/w
PDOMapping	Yes
Value Range	0...65,535
Default Value	0

**Index 5101: Output PWM Control**

With this index the controls for PWM are set up.  
 PWM is either activated with this very index directly  
 or an additional control via index 6200 is used.

Index	5101
Name	Output PWM Control
Description	-
Data Type	Array

Index	5101.00
Name	Number of indexes supported
Description	-
Data Type	Unsigned 8
Access	r/o
PDOMapping	No
Value Range	-
Default Value	2

Only bit 0 (PWM enable) and bit 1 (control output)  
 are functional.

Bit 0 = 0 (PWM disabled)

Bit 0 = 1 (PWM enabled)

Bit 1 = 0 (PWM direct activation)

Bit 1 = 1 (PWM activation via digital output)

Index	5101.01...5101.xx
Name	Output PWM Control
Description	
Data Type	Unsigned 16
Access	r/w
PDOMapping	No
Value Range	-
Default Value	0

**Index 5102: Output PWM Steps**

This index sets the number of steps for the PWM.

Index	5102
Name	Output PWM Value
Description	-
Data Type	Array

Index	5102.00
Name	Number of indexes supported
Description	-
Data Type	Unsigned 8
Access	r/o
PDOMapping	No
Value Range	-
Default Value	2

Index	5102.01...5102.xx
Name	Output PWM Value
Description	
Data Type	Unsigned 16
Access	r/w
PDOMapping	Yes
Value Range	0..65,535
Default Value	0

**Index 5107: Output PWM Prescaler**

This index sets a divisor (prescaler) of the PWM base frequency.

PWM frequency = 24 kHz (base frequency)/prescaler

Index	5107
Name	Output PWM Prescaler
Description	Prescaler for the PWM frequency
Data Type	Unsigned 16
Access	r/w
PDOMapping	No
Value Range	1..24000
Default Value	250

**Samples for producing PWM (duty-cycle 50/50)**

Frequencies faster 5 kHz result in a drifting duty-cycle (50/50, drift > 1%).

<b>Index 5100</b>	<b>Index 5102</b>	<b>Index 5107</b>	<b>Frequency in Hz</b>
1,000	2,000	240	50
500	1,000	480	50
20,000	40,000	12	50
5,000	10,000	48	50
2,400	4,800	1	5,000
200	480	10	5,000
500	1,000	24,000	1
5,000	10,000	24,000	0.1
25,000	50,000	24,000	0.02
32,767	65,535	24,000	0.015259...

## Emergency messages

All possible emergency messages of this device have the same structure as follows:

Byte							
0	1	2	3	4	5	6	7
EMY-Code		1001	0	CIO-Code			

EMY-Code: Error code according to DS301  
 1001: Value of index 1001  
 CIO-Code: Error code as unsigned 32-bit-value

CIO-Code (hex)	Change		Description
	NMT	I/O	
1000 0000	X	X	Heartbeat Consumer Error
2000 0000			Node-Guarding Warning
3000 0000	X	X	Lifeguarding Error
4000 0000			CAN is in Error-Warning-State
8000 0000	X	X	Device was Bus-Off

The Node-Guarding warning has to be activated with index 2103.

If more than one error occurs, the messages are combined by using logic OR.

Some errors have to change the NMT state and/or cause a change of the output states. This behavior depends on the settings of index 1029.

The ID for emergency messages is fixed to 0x80 + Node-ID.

### List of emergency messages:

A defined Heartbeat-Producer was not able to send the Heartbeat telegram.

Heartbeat Consumer Error							
30	81	01	00	00	00	00	10

The master is not able to do a RTR on the node.

Node-Guarding Warning							
30	81	01	00	00	00	00	20

The Lifeguarding time is up.

Life-Guarding Error							
30	81	11	00	00	00	00	30

The internal CAN module is in Error-Warning-State.

CAN is in Error-Warning-State							
00	81	01	00	00	00	00	40

Successful return from Bus-Off.

Return from Bus-Off							
40	81	01	00	00	00	00	80

**I/O Mapping (quick reference)**

2 digital inputs/2 digital outputs EDS file: ZILA-cIO-050.eds	
Mapping in object dictionary	
Index	mapped data
4000.00	Counter Value
4100.00	IN0 Period
4110.00	IN1 Period
4111.00	IN1 High Time
4112.00	IN1 Low Time
5100.01/5100.02	Output PWM Value 1/2
6000.01	Input 0.0...0.1
6200.01	Output 0.0...0.1

Default PDO Mapping	
PDO	mapped data
RPDO1	6200.01 Digital output 0.0...0.1
RPDO2	4001.01 Counter Control
RPDO3	Output PWM Value 1 Output PWM Value 2
TPDO1	6000.01 Digital inputs 0.0...0.1
TPDO2	4000.00 Counter Value
TPDO3	4100.00 IN0 Period
TPDO4	4110.00 IN1 Period 4111.00 IN1 High Time



## History

<b>Version</b>	<b>Release date</b>	<b>Changes/Remarks</b>
V1.440_R000	22.03.2013	First release
V1.570_R000	05.09.2014	Update firmware Change: PWM-Prescaler from min. 3 to min. 2 Change: PWM frequency from max. 8 kHz to max. 12 kHz
V1.570_R001	20.10.2014	Additional temperature range -40...+70 °C
V1.570_R002	18.02.2015	Update ordering information
V1.570_R003	03.11.2015	CAN baud rate 10 kBit/s deleted (no longer supported)
V1.720_R000	23.11.2015	Update firmware Change: PWM-Prescaler from min. 2 to min. 1 Change: PWM frequency from max. 12 kHz to max. 24 kHz
V2.100_R000	05.04.2017	Update firmware New: index 5102 PWM Steps Change: index 5100 from 0...1,000 to 0...65,535 New: Samples for producing PWM Release data sheet in new design

**TOC**

General .....	1
Features .....	1
CANopen Features.....	1
Ordering information .....	1
Technical data .....	2
Connectors assignment    Connector X1 (power) .....	3
Connector X2 (CAN).....	3
Connector X3 (digital outputs) .....	3
Connector X4 (digital inputs).....	3
Wiring diagram .....	4
Single supply .....	4
Dual supply.....	4
Triple supply.....	6
Configuration Dip-Switch .....	7
CANSignal-LED.....	7
Dimensions .....	8
CANopen Object Dictionary.....	9
DS301: global objects .....	9
Specific objects .....	11
DS401: digital inputs .....	12
DS401: digital outputs.....	12
Product related specific objects sorted by function .....	13
Counter .....	13
Pulse measuring.....	13
PWM.....	13
Object dictionary (description).....	14
DS301:Global objects .....	14
Index 0005 .....	14
Index 0006 .....	14
Index 0007.....	14
Index 1000: Device Type.....	15
Index 1001: Error Register .....	15
Index 1002: Status Register.....	15
Index 1005: COB-ID SYNC.....	16
Index 1008: Device Name .....	16
Index 1009: Hardware Version .....	16
Index 100A: Software Version .....	16
Index 100C: Guard Time.....	17
Index 100D: Life Time Factor .....	17
Index 100E: COB-ID Guard.....	17
Index 1014: COB-ID Emergency .....	17
Index 1015: Inhibit Time Emergency .....	18
Index 1017: Producer Heartbeat Time.....	18
Index 1029: Error Behavior .....	19

---

DS301: PDO Parameter Objects.....	20
Communication Parameter Objects.....	20
PDO mapping objects.....	22
Specific Objects.....	24
Index 2009: Serial Number 64 Bit.....	24
Index 2101: System Configuration.....	25
Index 2102: Remapping Enabled Info.....	25
Index 2105: Internal Error Code.....	25
Index 2110: Test Object.....	26
Index 2180: CAN Restart Time.....	26
DS401: digital inputs.....	27
Index 6100: Read Digital Input 16 Bit.....	27
Index 6120: Read Digital Input 32 Bit.....	27
Index 6002: Polarity Input 8 Bit.....	28
Index 6005: Global Interrupt Enable.....	28
Index 6006: Interrupt Mask Any Change.....	29
Index 6007: Interrupt Mask Low to High.....	29
Index 6008: Interrupt Mask High to Low.....	29
DS401: digital outputs.....	30
Index 6200: Write to Digital Output.....	30
Index 6300: Write Digital Output 16 Bit.....	30
Index 6320: Write Digital Output 32 Bit.....	30
Index 6206: Error Mode Output 8 Bit.....	31
Index 6207: Error Value Output 8 Bit.....	31
Product related specific objects sorted by function.....	32
Counter.....	32
Index 4000: Counter Value.....	32
Index 4001: Counter Control.....	32
Index 4008: Counter Mode.....	32
Index 4100: IN0 Period.....	32
Pulse measurement.....	33
Index 4110: IN1 Period.....	33
Index 4111: IN1 High Time.....	33
Index 4112: IN1 Low Time.....	34
PWM.....	35
Index 5100: Output PWM Value.....	35
Index 5101: Output PWM Control.....	36
Index 5102: Output PWM Steps.....	37
Index 5107: Output PWM Prescaler.....	37
Samples for producing PWM (duty-cycle 50/50).....	38
Emergency messages.....	39
List of emergency messages:.....	39
I/O Mapping (quick reference).....	40
History.....	41
TOC.....	42