

### General

The cIO-CAN-55 is a low-cost CANopen module with 4 analog input lines. The I/O are isolated from power supply and the CAN bus sub system. Furthermore, the module has an input resolution of 16 bit and a voltage range of -10...+10 volt.

Direct links with other I/O modules of the cIO-CAN series are possible without a master PLC.

CANopen is available according to DS301 and DS401. All usual baud rates up to 1 Mbit/s supported.



### Features

- 4 analog inputs isolated from CAN and supply
- Voltage range selectable:  
-10...+10V
- Receiving of values without PLC/CAN-Master from suitable counterpart module possible
- Plastic housing for mounting onto DIN carrier rails
- Operating temperature 0...+55 °C (opt. -40...+70 °C)

### CANopen Features

- CAN baud rates up to 1 Mbit/s
- CAN bus ISO11898 with Transceiver TJA1050
- 4 Transmit- and 4 Receive-PDO
- Dynamic PDO Mapping
- Variable PDO Identifier
- CANopen PDO transfer modes: synchronous, asynchronous, event triggered, cyclic, acyclic and RTR
- Event Timer and Inhibit Timer for all Transmit-PDO
- Node-Guarding, Lifeguarding und Heartbeat
- Emergency messages
- Minimum Boot-Up

### Ordering information

Part	Order number
cIO-CAN-55	4000-1-0009
4 analog inputs, CAN isolated, 0...+55 °C	
cIO-CAN-55e	4000-1-0010
4 analog inputs, CAN isolated, -40...+70 °C	

## Technical data

Separated potentials for system/bus and inputs

<b>Power supply System</b>	<b>Min.</b>	<b>Norm.</b>	<b>Max.</b>
Supply voltage System/Bus	+11VDC	+24 V DC	+32 V DC
Current consumption System/Bus	+43 mA (at V <sub>CC</sub> = +32 V DC)	+55 mA	+112 mA (at V <sub>CC</sub> = +11VDC)
CAN bus Norm	ISO11898		
CiA Draft Standards	DS301 Version 4.0 and DS401 Version 2.0		
Conformance declaration	CE		
MTBF	4,742,234 hrs		

<b>Analog inputs</b>	
Number of inputs	4
Resolution	16 Bit (15 Bit plus sign)
Absolute max. input voltage	± 60 VDC
Isolation between System/Bus	60 V DC
Voltage range output lines	-10...+10V
Delay (CAN reaction time)	typ. 1 ms

<b>Reference outputs</b>	
Output voltage	+10 VDC
Max. output current	+10 mA
Short circuit-proof, duration	Yes, 1s

<b>Connectors and dimensions</b>	
Connectors	Screw clamps
Cable cross-section [mm <sup>2</sup> ]	0.08...1.5 mm <sup>2</sup> (massive/flexible)
Cable cross-section [AWG]	26...14 AWG (massive/flexible)
Stripping length	8 mm
Dimensions housing	approx. 17.8 x 90 x 62 mm (see picture "dimensions"!)
Operating temperature	0...+55 °C (optional -40...+70 °C)

**Connectors assignment**

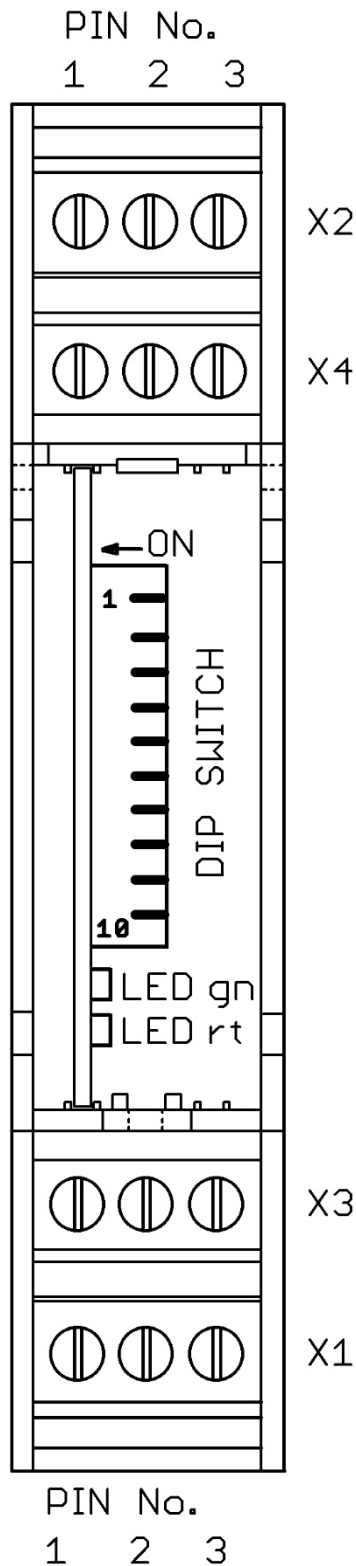

**Connector X1 (power)**

Pin-No.	Name	Description
1	U	+24VDC
2	GND	Ground
3	RO	Reference output

**Connector X2 (CAN)**

Pin-No.	Name	Description
1	L0	CANLow
2	H0	CANHigh
3	G0	Ground

**Connector X3 (inputs)**

Pin-No.	Name	Description
1	I1	Input 1
2	G1	Ground
3	I2	Input 2

**Connector X4 (inputs)**

Pin-No.	Name	Description
1	I3	Input 3
2	G1	Ground
3	I4	Input 4

## Wiring diagram

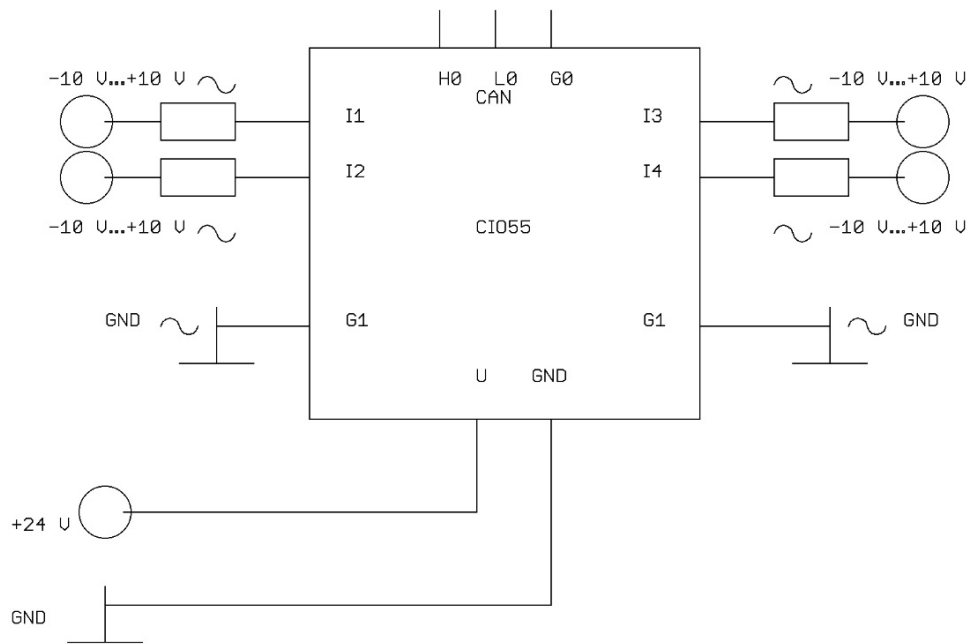

## Information to direct links

It is possible to create direct links to other devices of the cIO-CAN series with this device. Matching modules are needed for this feature.

With a direct link a fail-safe transmission of analog values is provided within the reach of strong electric machines, e.g. electric motors, or over great distances.

It is even possible to add such a direct link into already existing CAN sub-systems. The modules are wired and the CAN connections linked.

### Configuration Dip-Switch

Configuration of node-ID, baud rate and termination via DIP-Switch.  
The switches are inside the housing (open lid).

Switch Number										Description
1	2	3	4	5	6	7	8	9	10	
RT										RT Termination CAN-Bus
	BD2	BD1	BD0							BDx Baud rate CAN-Bus
				ID5	ID4	ID3	ID2	ID1	ID0	IDx Select Node-ID
ON										CAN-Termination on (120 Ohm)
OFF										CAN-Termination off
	OFF	OFF	OFF							1 MBit/s
	OFF	OFF	ON							800 kBit/s
	OFF	ON	OFF							500 kBit/s
	OFF	ON	ON							250 kBit/s
	ON	OFF	OFF							125 kBit/s
	ON	OFF	ON							50 kBit/s
	ON	ON	OFF							20 kBit/s
	ON	ON	ON							Reserved
				OFF	OFF	OFF	OFF	OFF	OFF	Reserved
				OFF	OFF	OFF	OFF	OFF	ON	Node-ID = 1
				OFF	OFF	OFF	OFF	ON	OFF	Node-ID = 2
				OFF	OFF	OFF	OFF	ON	ON	Node-ID = 3
				...	...	...	...	...	...	...
				ON	ON	ON	ON	OFF	OFF	Node-ID = 60
				ON	ON	ON	ON	OFF	ON	Node-ID = 61
				ON	ON	ON	ON	ON	OFF	Node-ID = 62
				ON	ON	ON	ON	ON	ON	Node-ID = 63

### CAN Signal-LED

The LED are located behind the lid. States are coded according to DRP303-3.

LED	Color	Description
RUN-LED	Green	off no supply or faulty flickering CANnot started flashing Stopped blinking Preoperational on Operational
ERR-LED	red	off no error 1x flashing CAN module in Error Warning State 2x flashing Node-Guarding error on Bus-Off

**Dimensions**

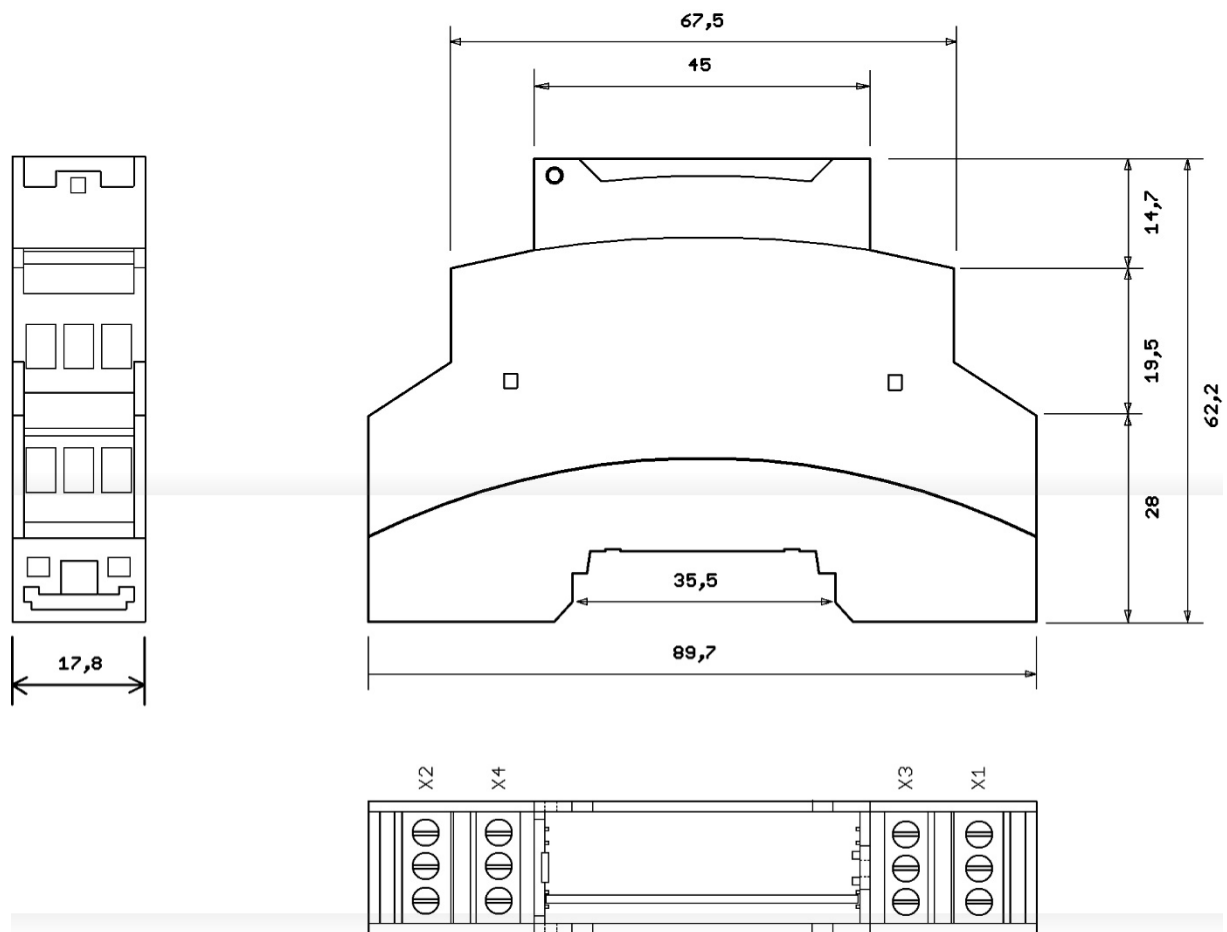

All measurements in millimeter (mm)

## CANopen Object Dictionary

### DS301: global objects

Index	Sub-Index	Name	Access
0005	-	Dummy 8	r/o
0006	-	Dummy 16	r/o
0007	-	Dummy32	r/o
1000	-	Device Type	r/o
1001	-	Error Register	r/o
1002	-	Manufacturer Status Register	r/o
1005	-	COB-ID SYNC	r/o
1008	-	Device Name	r/o
1009	-	Hardware Version	r/o
100A	-	Software Version	r/o
100C	-	Guard Time	r/w
100D	-	Life Time Factor	r/w
100E	-	COB-ID Guard	-
1014	-	COB ID Emergency	r/w
1015	-	Inhibit Time Emergency	r/w
1016	0	Consumer Heartbeat Time	r/o
	1	Consumer Heartbeat Time 1	r/w
	2	Consumer Heartbeat Time 2	r/w
	3	Consumer Heartbeat Time 3	r/w
	4	Consumer Heartbeat Time 4	r/w
1017	-	Producer Heartbeat Time	r/w
1029		Error Behavior Object	r/o
	1	Communication error	r/w
	2	Application error	r/w

All index values are hexadecimal. Values in tables are hexadecimal (0x...) or decimal.

r/o      read only  
w/o      write only  
r/w      read and write

All visible string data types are 20 characters at max.

**DS301: PDO Parameter objects**

Description of PDO Parameter. With these indexes, dynamic PDO-Mapping, free selection of IDs, transmission type, inhibit and event time is possible. These settings are selectable in "operational" as well as "preoperational" mode.

Index	Sub-Index	Name	Access
1400	0	Receive-PDO1 Communication Parameter	r/o
	1	COB-ID	r/w
	2	Transmission Type	r/w
1401...1403		Receive-PDO2 to RPDO4 Communication Parameter same as 1400	r/w
1600	0	Receive-PDO1 Parameter mapping	r/w
	1 to n	Mapped objects (max. 8 objects mappable)	r/w
1601...1603		Receive-PDO2 to RPDO4 Parameter mapping same as 1600	r/w
1800	0	Transmit-PDO1 Communication Parameter	r/o
	1	COB-ID	r/w
	2	Transmission Type	r/w
	3	Inhibit Time	r/w
	4	Reserved	r/w
	5	Event Time	r/w
1801...1803		Transmit-PDO2 to TPDO4 Communication Parameter same as 1800	r/w
1A00	0	Transmit-PDO1 Parameter mapping	r/w
	1 to n	Mapped objects (max. 8 objects mappable)	r/w
1A01...1A03		Transmit-PDO2 to TPDO4 Parameter mapping same as 1A00	r/w



**Specific objects**

Index	Sub-Index	Name	Access
2009	0	Serial Number 64 Bit	r/o
	1	Serial Number 64 Bit LSDW	r/o
	2	Serial Number 64 Bit MSDW	r/o
2101	-	System Configuration	r/o
2102	-	Remapping Enabled Info	r/o
2103	-	Enable Guarding Warning	r/w
2105	-	Internal API State	r/o
2110	0	Conformance Test Object	r/o
	1	Range Check Object	r/w
2180	-	CAN Restart Time	r/w

**DS401: analog inputs**

Index	Sub-Index	Name	Access
5300	-	Analog Input Mode	r/w
5301	-	Analog Input Filter Level	r/w
5310	-	Input Calibration	r/w
6401	0 to n	Analog Input 16 Bit	r/w
6421	0 to n	Analog Input Trigger Selection	r/w
6423	-	Analog Interrupt Enable	r/w
6424	0 to n	Analog Input Interrupt Upper Limit	r/w
6425	0 to n	Analog Input Interrupt Lower Limit	r/w
6426	0 to n	Analog Input Interrupt Delta	r/w
6427	0 to n	Analog Input Interrupt Negative Delta	r/w
6428	0 to n	Analog Input Interrupt Positive Delta	r/w

**Product related specific objects sorted by function**

Index	Sub-Index	Name	Access
2EFF	-	Direct Link	r/w

**Object dictionary (description)**

Following comes a short description of every dictionary entry.

**DS301: Global objects****Index 0005**

Dummy for spaces in PDO mapping (8-bit length).  
Can be used, more than once.

Index	0005
Name	Dummy 8
Description	
Data Type	Unsigned 8
Access	r/o
PDO Mapping	Yes
Value Range	-
Default Value	0

**Index 0006**

Dummy for spaces in PDO mapping (16-bit length).  
Can be used, more than once.

Index	0006
Name	Dummy 16
Description	
Data Type	Unsigned 16
Access	r/o
PDO Mapping	Yes
Value Range	-
Default Value	0

**Index 0007**

Dummy for spaces in PDO mapping (32-bit length).  
Can be used, more than once.

Index	0007
Name	Dummy 32
Description	
Data Type	Unsigned 32
Access	r/o
PDO Mapping	Yes
Value Range	-
Default Value	0

**Index 1000: Device Type**

This index contains a description of the device type. Within are encoded the CiA profile code and additional specifications of the device.

Index	1000
Name	Device Type
Description	-
Data Type	Unsigned 32
Access	r/o
PDOMapping	No
Value Range	-
Default Value	0x0083 0191

**Index 1001: Error Register**

This index contains the internal error code in case of emergency.

Index	1001
Name	Error Register
Description	-
Data Type	Unsigned 8
Access	r/o
PDOMapping	Yes
Value Range	-
Default Value	-

The error register is built as shown. If more than one error occur, the values are combined via logical OR.

Bit	Description
0	Common error. This bit is set with every error.
1	0
2	0
3	0
4	CAN bus or communication error
5	0
6	0
7	Device error

**Index 1002: Status Register**

This index contains additional status information of the device.

Index	1002
Name	Status Register
Description	-
Data Type	Unsigned 32
Access	r/o
PDOMapping	Yes
Value Range	-
Default Value	-

**Index 1005: COB-ID SYNC**

This index sets the COB-ID for SYNC messages.

This device is a receiving device. SYNC production is not supported.

Index	1005
Name	COB-ID Sync
Description	-
Data Type	Unsigned 32
Access	r/w
PDO Mapping	No
Value Range	1...0x7FF
Default Value	0x80

**Index 1008: Device Name**

This index contains the device name as a visible string.

<sup>1)</sup> xxx: Number of the product

Index	1008
Name	Device Name
Description	-
Data Type	Visible String
Access	r/o
PDO Mapping	No
Value Range	The maximum string length is 20 characters
Default Value	"hipecs-CIOxxx <sup>1)</sup> "

**Index 1009: Hardware Version**

This index contains the revision code of the hardware as visible string.

Index	1009
Name	Hardware Version
Description	-
Data Type	Visible String
Access	r/o
PDO Mapping	No
Value Range	The maximum string length is 20 characters
Default Value	-

**Index 100A: Software Version**

This index contains the firmware version as visible string.

Index	100A
Name	Software Version
Description	-
Data Type	Visible String
Access	r/o
PDO Mapping	No
Value Range	The maximum string length is 20 characters
Default Value	-

**Index 100C: Guard Time**

Together with index 100D, this index represents the lifeguarding protocol. Values are in milliseconds.

Guard Time multiplied by Life Time Factor results in Life Time.

Set up 0 (zero), if not used.

Index	100C
Name	Guard Time
Description	-
Data Type	Unsigned 16
Access	r/w
PDOMapping	No
Value Range	
Default Value	0

**Index 100D: Life Time Factor**

Together with index 100C, this index represents the lifeguarding protocol. Values are factors.

Guard Time multiplied by Life Time Factor results in Life Time.

Set up with 0 (zero), if not used.

Index	100D
Name	Life Time Factor
Description	-
Data Type	Unsigned 8
Access	r/w
PDOMapping	No
Value Range	
Default Value	0

**Index 100E: COB-ID Guard**

This index contains the ID for guarding protocol.

Index	100E
Name	COB-ID Guard
Description	-
Data Type	Unsigned 32
Access	-
PDOMapping	No
Value Range	-
Default Value	0x700 + Node-ID

**Index 1014: COB-ID Emergency**

This index sets the ID for emergency messages.

Index	1014
Name	COB-ID Emergency
Description	-
Data Type	Unsigned 32
Access	r/w
PDOMapping	No
Value Range	-
Default Value	0x80 + Node-ID

**Index 1015: Inhibit Time Emergency**

This index sets up a delay for transmitting any emergency. This device supports a delay with an interval of one millisecond.

Index	1015
Name	Inhibit Time Emergency
Description	-
Data Type	Unsigned 16
Access	r/w
PDO Mapping	No
Value Range	-
Default Value	0 (disabled)

**Index 1016: Consumer Heartbeat Time**

Index 1016 is used to monitor the Heartbeat Consuming of up to four nodes.

Index	1016
Name	Consumer Heartbeat Time
Description	-
Data Type	Structure

**Attention:**

Heartbeat monitoring starts with the reception of the first heartbeat.

The Producer Time should be greater than the Consumer Time.

Ahead of the first heartbeat, the Producers status is unknown.

Index	1016.00
Name	Number of indexes supported
Description	-
Data Type	Unsigned 8
Access	r/o
PDO Mapping	No
Value Range	-
Default Value	4

**Structure of the Consumer Heartbeat Time**

MSB		LSB	
Byte3	Byte2	Byte1	Byte0
Reserved	Node-ID	Heartbeat time	

Index	1016.01...1016.04
Name	Consumer Heartbeat Time 1...4
Description	-
Data Type	Unsigned 32
Access	r/w
PDO Mapping	No
Value Range	-
Default Value	0

**Index 1017: Producer Heartbeat Time**

This index sets up the heartbeat cycle in an interval of one millisecond.

If it is not used, set up 0 (zero).

**Attention:**

Use either Heartbeat or Node-Guarding. Both at once is not allowed.

Index	1017
Name	Producer Heartbeat Time
Description	-
Data Type	Unsigned 16
Access	r/w
PDO Mapping	No
Value Range	-
Default Value	0

**Index 1029: Error Behavior**

This index sets up whether the device switches its operating state in case of emergency, or not. Possible changes are Pre-Operational or Stopped. No change at all and keeping the current state is possible, too.

Index	1029
Name	Error Behavior Object
Description	-
Data Type	Structure

As communication error counts, e.g., Bus-Off, Heartbeat, Guarding or internal errors of the device.

Index	1029.00
Name	Number of indexes supported
Description	-
Data Type	Unsigned char
Access	r/o
PDOMapping	No
Value Range	-
Default Value	2

The values of the states are as follows:

- 0 Pre-Operational (only if Operational)
- 1 no change
- 2 Stopped
- 3..255 reserved

Index	1029.01
Name	Communication Error
Description	NMT state change in case of communication error
Data Type	Unsigned 8
Access	r/w
PDOMapping	No
Value Range	-
Default Value	0

Index	1029.02
Name	Application Error
Description	NMT state change in case of internal error due to hardware malfunction
Data Type	Unsigned 8
Access	r/w
PDOMapping	No
Value Range	-
Default Value	0

## DS301: PDO Parameter Objects

### Communication Parameter Objects

The transmission type for Transmit- and Receive-PDO are set up with sub-index 2.

Type	PDO transmission				
	cyclic	acyclic	synchronous	asynchronous	RTR
0		X	X		
1-240	X		X		
241-251	Reserved				
252			X		X
253				X	X
254				X	
255				X	

The synchronous transmission types 0...240 and 252 are dependent on the SYNC signal. Asynchronous transmission is independent from the SYNC.

Type 0 is triggered by the SYNC, however, a transmission is only made, if the PDO data changes.

A value between 1 and 240 says the transmission is synchronous and cyclic. The transmission type represents the needed number of SYNCs for triggering the PDO.

Type 252 triggers a transmission with the next available SYNC, but only if a RTR releases the PDO. Type

253 transmits the PDO immediately, however, only on RTR.

With type 254 and 255, the manufacturer or the device profile set the conditions.

An inhibit time can be set in sub-index 3. The PDO are triggered by their conditions, but only transmitted if the inhibit time is up. This time is set as a multiple of 100 µs, a value of 0 (zero) renders the function useless.

In mode 254/255, an additional Event Time is set. This timer running out is considered an event. The time is set as a multiple of 1 ms. This event triggers a PDO transmission in addition to other possible events.

Index 1400 is an example for Receive-PDO and index 1800 is an example for Transmit-PDO.

Index	PDO
1400...14xx	Receive-PDO1...Receive-PDOxx
1800...18xx	Transmit-PDO1...Transmit-PDOxx

Index	14xx/18xx
Name	Receive-/Transmit-PDOx Communication Parameters
Description	-
Data Type	Structure

Index	14xx.00/18xx.00
Name	Number of indexes supported
Description	-
Data Type	Unsigned 8
Access	r/o
PDOMapping	No
Value Range	-
Default Value	2/5



1400.01	ID + 80000200	1800.01	ID + 80000180
1401.01	ID + 80000300	1801.01	ID + 280
1402.01	ID + 80000400	1802.01	ID + 80000380
1403.01	ID + 80000500	1803.01	ID + 80000480

Index	14xx.01/18xx.01
Name	COB-ID
Description	Identifier for CAN-Object for PDO
Data Type	Unsigned 32
Access	r/w
PDO Mapping	No
Value Range	-
Default Value	

The table shows the default PDO-ID values.  
An Identifier von 8xxxxxxx means the PDO is rendered inactive. The CAN master has to assign a valid PDO-ID.

See table on top of the chapter.

Index	14xx.02/18xx.02
Name	Transmission Type
Description	-
Data Type	Unsigned 8
Access	r/w
PDO Mapping	No
Value Range	-
Default Value	0xFF

Multiple of 1 µs.

Index	18xx.03
Name	Inhibit Time
Description	-
Data Type	Unsigned 16
Access	r/w
PDO Mapping	No
Value Range	-
Default Value	0

Index	18xx.04
Name	Reserved
Description	-
Data Type	-
Access	-
PDO Mapping	No
Value Range	-
Default Value	-

Multiple of 1 ms.

Index	18xx.05
Name	Event Time
Description	-
Data Type	Unsigned 16
Access	r/w
PDO Mapping	No
Value Range	-
Default Value	0

**PDO mapping objects**

The following table shows the PDO mapping entries. This is the same for all PDO. The mapping table is a linking index for entries of the object dictionary (e.g. data of digital outputs) and position in the PDO.

Sub-Index 0 gives the number of valid entries. The cIO-CAN-55 supports up to eight entries each PDO. In order to change the mapping, sub-index 0 has to be set to 0 (zero) first (inactive). Now the entries can be altered. If a new entry is mapped, the cIO-CAN-55 checks whether the entry is valid or not. Invalid entries result in an abort.

All eight sub-indexes are pointer to the entries. A value of 0 (zero) means no entry. The pointer's structure is:

MSB		LSB	
Byte3	Byte2	Byte1	Byte0
mapped index		sub-index	Length

Index and sub-index combined are the pointer; Length is the data length of the pointer's target in bit.

Index	160x/1A0x
Name	Receive-/Transmit-PDO Mapping Parameters
Description	-
Data Type	Array

Index	160x/1A0x.00
Name	Number of indexes supported
Description	Number of mapped objects
Data Type	Unsigned 8
Access	r/w
PDO Mapping	No
Value Range	-
Default Value	See table below

Index	160x/1A0x.01...160x/1A0x.08
Name	Mapped object
Description	
Data Type	Unsigned 32
Access	r/w
PDO Mapping	No
Value Range	-
Default Value	See table below

**Receive-PDO**

The cIO-CAN-55 uses this default configuration for Receive-PDO.

Index	Entry	
Receive-PDO1		
1600.00	0	
Receive-PDO2		
1601.00	0	
Receive-PDO3		
1602.00	0	
Receive-PDO4		
1603.00	0	

**Transmit-PDO**

The cIO-CAN-55 uses this default configuration for Transmit-PDO.

Index	Entry	
Transmit-PDO1		
1A00.00	0	
Transmit-PDO2		
1A01.00	4	
1A01.01	64010110	Analog input 1
1A01.02	64010210	Analog input 2
1A01.03	64010310	Analog input 3
1A01.04	64010410	Analog input 4
Transmit-PDO3		
1A02.00	0	
Transmit-PDO4		
1A03.00	0	

## Specific Objects

### Index 2009: Serial Number 64 Bit

This index contains the serial number of this device.

Index	2009
Name	Serial Number 64 Bit
Description	-
Data Type	Array

Index	2009.00
Name	Number of indexes supported
Description	-
Data Type	Unsigned 8
Access	r/o
PDO Mapping	No
Value Range	-
Default Value	2

Index	2009.01
Name	Serial Number Low Double Word
Description	Bits 0...31 of the serial number
Data Type	Unsigned 32
Access	r/o
PDO Mapping	No
Value Range	-
Default Value	-

Index	2009.02
Name	Serial Number High Double Word
Description	Bits 32...63 of the serial number
Data Type	Unsigned 32
Access	r/o
PDO Mapping	No
Value Range	-
Default Value	-

**Index 2101: System Configuration**

This index shows the current operating mode of the device.

Index	2101
Name	System Configuration
Description	-
Data Type	Unsigned 32
Access	r/o
PDOMapping	No
Value Range	-
Default Value	0

**Index 2102: Remapping Enabled Info**

This index shows, whether remapping the PDO is allowed or prohibited.

- 0 = remapping prohibited
- 1 = remapping allowed

Index	2102
Name	Remapping Enabled Info
Description	-
Data Type	Unsigned 8
Access	r/o
PDOMapping	No
Value Range	-
Default Value	1

**Index 2103: Enabled Guarding Warning**

This index enables an additional warning when Node-Guarding is used.

The CAN master is given an early report for an imminent Node-Guarding failure.  
 The warning is triggered when the Guard Time is up (Index 100C).  
 The NMT state remains unaffected.

Index	2103
Name	Enable Guarding Warning
Description	-
Data Type	Unsigned 8
Access	r/w
PDOMapping	No
Value Range	-
Default Value	0

**Index 2105: Internal Error Code**

These are internal error messages of the CANopen controller.

Index	2105
Name	Internal Error Code
Description	-
Data Type	Unsigned 32
Access	r/o
PDOMapping	Yes
Value Range	-
Default Value	0 (no error condition)

**Index 2110: Test Object**

This index is for internal test purposes only. It possesses no function and is not to use.

Index	2110
Name	Test Object 01
Description	-
Data Type	Structure

Index	2110.00
Name	Number of indexes supported
Description	-
Data Type	Unsigned char
Access	r/o
PDO Mapping	No
Value Range	-
Default Value	1

Index	2110.01
Name	Range Check Object
Description	-
Data Type	Unsigned 16
Access	r/w
PDO Mapping	No
Value Range	100...1000
Default Value	500

**Index 2180: CAN Restart Time**

With this index, the restart time for the CAN communication in case of a Bus-Off error is defined. The value is set in milliseconds.

0 (zero) disables this function.

Index	2180
Name	CAN Restart Time
Description	-
Data Type	Unsigned 16
Access	r/w
PDO Mapping	No
Value Range	0...50000
Default Value	1000 (restart after one second)

**DS401: analog inputs****Index 5300: Analog Input Mode**

This index determines the input range and whether the input values are given in millivolts or hexadecimal form.

Bit 0 = 0: input voltage range 0...+10 V

Bit 0 = 1: input voltage range -10 V...+10 V

Bit 1 = 0: input scaling in hexadecimal form

Bit 1 = 1: input scaling in millivolts

Index	5300
Name	Analog Input Mode
Description	
Data Type	Unsigned 16
Access	r/w
PDOMapping	No
Value Range	-
Default Value	3

**Index 5301: Analog Input Filter Level**

This index sets the size of the internal filter for the input lines.

Index	5301
Name	Analog Input Filter Level
Description	
Data Type	Unsigned 16
Access	r/w
PDOMapping	No
Value Range	0...20
Default Value	10

**Index 5310: Input Calibration****Attention:**

This index is for internal purposes only and is not to be used!

Index	5310
Name	Input Calibration
Description	
Data Type	-
Access	-/-
PDOMapping	No
Value Range	-
Default Value	-

**Index 6401: Read Analog Input**

With this index, the analog inputs are read.

Index	6401
Name	Read Analog Input
Description	-
Data Type	Array

Index	6401.00
Name	Number of indexes supported
Description	
Data Type	Unsigned 8
Access	r/o
PDOMapping	No
Value Range	-
Default Value	-

Index	6401.01...6401.xx
Name	Read analog input
Description	
Data Type	Signed 16
Access	r/o
PDOMapping	Yes
Value Range	-
Default Value	-

**Index 6421: Analog Input Interrupt Trigger**

With this index, the user selects the trigger conditions.

Index	6421
Name	Analog Input Interrupt Trigger
Description	-
Data Type	Array

Index	6421.00
Name	Number of indexes supported
Description	
Data Type	Unsigned 8
Access	r/o
PDOMapping	No
Value Range	-
Default Value	-

- Bit 0: Input voltage greater than upper level
- Bit 1: Input voltage less than lower level
- Bit 2: Input changed more than delta
- Bit 3: Input reduced more than negative delta
- Bit 4: Input increased more than positive delta
- Bit 5...7: reserved (must be forced to 0 (zero))

Index	6421.01...6421.xx
Name	Analog Input Interrupt Trigger
Description	
Data Type	Unsigned 8
Access	r/w
PDOMapping	Yes
Value Range	-
Default Value	7



**Index 6423: Analog Input Interrupt Enable**

This index enables/disables the global interrupt for analog input signals.

Disabled by default, to avoid bus overloads because of analog transmissions.

1 (true): enabled

0 (false): disabled

Index	6423
Name	Analog Input Interrupt Enable
Description	
Data Type	Boolean
Access	r/w
PDOMapping	No
Value Range	-
Default Value	0 (false)

**Index 6424: Analog Input Upper Limit**

With this index, the upper limits for analog interrupts are set (for signal  $\geq$  limit).

Index	6424
Name	Analog Input Upper Limit
Description	-
Data Type	Array

Index	6424.00
Name	Number of indexes supported
Description	
Data Type	Unsigned 8
Access	r/o
PDOMapping	No
Value Range	-
Default Value	-

Index	6424.01...6424.xx
Name	Analog Input Upper Limit
Description	
Data Type	Integer 32
Access	r/w
PDOMapping	No
Value Range	-
Default Value	0

**Index 6425: Analog Input Lower Limit**

With this index, the lower limits for analog interrupts are set (for signal < limit).

Index	6425
Name	Analog Input Lower Limit
Description	-
Data Type	Array

Index	6425.00
Name	Number of indexes supported
Description	
Data Type	Unsigned 8
Access	r/o
PDOMapping	No
Value Range	-
Default Value	-

Index	6425.01...6425.xx
Name	Analog Input Lower Limit
Description	
Data Type	Integer 32
Access	r/w
PDOMapping	No
Value Range	-
Default Value	0

**Index 6426: Analog Input Interrupt Delta**

With this index, the signal changes (delta) for analog interrupts are set (any change at all, reducing or increasing).

Index	6426
Name	Analog Input Interrupt Delta
Description	-
Data Type	Array

Index	6426.00
Name	Number of indexes supported
Description	
Data Type	Unsigned 8
Access	r/o
PDOMapping	No
Value Range	-
Default Value	-

Index	6426.01...6426.xx
Name	Analog Input Interrupt Delta
Description	
Data Type	Integer 32
Access	r/w
PDOMapping	No
Value Range	-
Default Value	0

**Index 6427: Analog Input Negative Delta**

With this index, the negative signal changes (delta) for analog interrupts are set (reducing only).

Index	6427
Name	Analog Input Negative Delta
Description	-
Data Type	Array

Index	6427.00
Name	Number of indexes supported
Description	
Data Type	Unsigned 8
Access	r/o
PDOMapping	No
Value Range	-
Default Value	-

Index	6427.01...6427.xx
Name	Analog Input Negative Delta
Description	
Data Type	Integer 32
Access	r/w
PDOMapping	No
Value Range	-
Default Value	0

**Index 6428: Analog Input Positive Delta**

With this index, the positive signal changes (delta) for analog interrupts are set (increasing only).

Index	6428
Name	Analog Input Positive Delta
Description	-
Data Type	Array

Index	6428.00
Name	Number of indexes supported
Description	
Data Type	Unsigned 8
Access	r/o
PDOMapping	No
Value Range	-
Default Value	-

Index	6428.01...6428.xx
Name	Analog Input Positive Delta
Description	
Data Type	Integer 32
Access	r/w
PDOMapping	No
Value Range	-
Default Value	0

**Product related specific objects sorted by function****Direkt link****Index 2EFF: Direct Link**

With this index, a direct link between two CAN nodes is established.

There is no need for a master PLC in this case.

Attention:

This index is not to be used by the user! Automatic use, when using direct link!

Index	2EFF
Name	Direct Link
Description	
Data Type	Unsigned 32
Access	r/w
PDO Mapping	No
Value Range	-
Default Value	-

## Emergency messages

All possible emergency messages of this device have the same structure as follows:

Byte							
0	1	2	3	4	5	6	7
EMY-Code		1001	0	CIO-Code			

EMY-Code: Error code according to DS301  
 1001: Value of index 1001  
 CIO-Code: Error code as unsigned 32-bit-value

CIO-Code (hex)	Change		Description
	NMT	I/O	
1000 0000	X	X	Heartbeat Consumer Error
2000 0000			Node-Guarding Warning
3000 0000	X	X	Lifeguarding Error
4000 0000			CAN is in Error-Warning-State
8000 0000	X	X	Device was Bus-Off

The Node-Guarding warning has to be activated with index 2103.

If more than one error occurs, the messages are combined by using logic OR.

Some errors have to change the NMT state and/or cause a change of the output states. This behavior depends on the settings of index 1029.

The ID for emergency messages is fixed to 0x80 + Node-ID.

### List of emergency messages:

A defined Heartbeat-Producer was not able to send the Heartbeat telegram.

Heartbeat Consumer Error							
30	81	01	00	00	00	00	10

The master is not able to do a RTR on the node.

Node-Guarding Warning							
30	81	01	00	00	00	00	20

The Lifeguarding time is up.

Life-Guarding Error							
30	81	11	00	00	00	00	30

The internal CAN module is in Error-Warning-State.

CAN is in Error-Warning-State							
00	81	01	00	00	00	00	40

Successful return from Bus-Off.

Return from Bus-Off							
40	81	01	00	00	00	00	80

**I/O Mapping (quick reference)**

4 analog inputs EDS file: ZILA-cIO-055.eds	
Mapping in object dictionary	
Index	mapped data
6401.01	Analog input 1
6401.02	Analog input 2
6401.03	Analog input 3
6401.04	Analog input 4

Default PDO Mapping	
PDO	mapped data
TPDO2	Analog input 1 Analog input 2 Analog input 3 Analog input 4

<sup>1)</sup> yyy: Number of the product

## History

<b>Version</b>	<b>Release date</b>	<b>Changes/Remarks</b>
V1.520_R000	04.11.2013	First release
V1.520_R001	21.10.2014	Update: temperature range
V1.520_R002	18.02.2015	Update: ordering information
V1.520_R003	26.03.2015	Errors corrected (object dictionary: analog input mode)
V1.520_R004	04.11.2015	CAN baud rate 10 kBit/s deleted (no longer supported)
V2.000_R000	29.04.2016	Update Firmware New: Index 2EFF (Direct Link)
V2.000_R001	05.04.2017	Release data sheet in new design

**TOC**

General .....	1
Features .....	1
CANopen Features.....	1
Ordering information .....	1
Technical data .....	2
Connector X2 (CAN).....	3
Connector X3 (inputs).....	3
Connector X4 (inputs).....	3
Wiring diagram .....	4
Configuration Dip-Switch .....	5
CANSignal-LED.....	5
Dimensions .....	6
CANopen Object Dictionary.....	7
DS301: global objects.....	7
DS301: PDO Parameter objects.....	8
Specific objects .....	9
DS401: analog inputs.....	9
Product related specific objects sorted by function .....	9
Object dictionary (description).....	10
DS301:Global objects .....	10
Index 0005 .....	10
Index 0006.....	10
Index 0007.....	10
Index 1000: Device Type.....	11
Index 1001: Error Register .....	11
Index 1002: Status Register.....	11
Index 1005: COB-ID SYNC.....	12
Index 1008: Device Name .....	12
Index 1009: Hardware Version.....	12
Index 100A: Software Version.....	12
Index 100C: Guard Time.....	13
Index 100D: Life Time Factor .....	13
Index 100E: COB-ID Guard.....	13
Index 1014: COB-ID Emergency .....	13
Index 1015: Inhibit Time Emergency .....	14
Index 1017: Producer Heartbeat Time.....	14
Index 1029: Error Behavior .....	15
DS301: PDO Parameter Objects.....	16
Communication Parameter Objects.....	16
PDO mapping objects .....	18
Specific Objects .....	20
Index 2009: Serial Number 64 Bit.....	20



---

Index 2101: System Configuration .....	21
Index 2102: Remapping Enabled Info .....	21
Index 2105: Internal Error Code.....	21
Index 2110: Test Object.....	22
Index 2180: CAN Restart Time .....	22
DS401: analog inputs .....	23
Index 5300: Analog Input Mode .....	23
Index 5301: Analog Input Filter Level.....	23
Index 5310: Input Calibration.....	23
Index 6401: Read Analog Input .....	24
Product related specific objects sorted by function.....	28
Direkt link .....	28
Index 2EFF: Direct Link.....	28
Emergency messages .....	29
List of emergency messages:.....	29
I/O Mapping (quick reference) .....	30
History .....	31
TOC.....	32